

1965

# On a cut-set to mesh transformation

Larry Bernard Coady  
*Iowa State University*

Follow this and additional works at: <https://lib.dr.iastate.edu/rtd>

 Part of the [Electrical and Electronics Commons](#)

## Recommended Citation

Coady, Larry Bernard, "On a cut-set to mesh transformation " (1965). *Retrospective Theses and Dissertations*. 3339.  
<https://lib.dr.iastate.edu/rtd/3339>

This Dissertation is brought to you for free and open access by the Iowa State University Capstones, Theses and Dissertations at Iowa State University Digital Repository. It has been accepted for inclusion in Retrospective Theses and Dissertations by an authorized administrator of Iowa State University Digital Repository. For more information, please contact [digirep@iastate.edu](mailto:digirep@iastate.edu).

This dissertation has been  
microfilmed exactly as received

66-3861

COADY, Larry Bernard, 1933-  
ON A CUT-SET TO MESH TRANSFORMATION.

Iowa State University of Science and Technology  
Ph.D., 1965  
Engineering, electrical

University Microfilms, Inc., Ann Arbor, Michigan

ON A CUT-SET TO MESH TRANSFORMATION

by

Larry Bernard Coady

A Dissertation Submitted to the  
Graduate Faculty in Partial Fulfillment of  
the Requirements for the Degree of  
DOCTOR OF PHILOSOPHY

Major Subject: Electrical Engineering

Approved:

Signature was redacted for privacy.

In Charge of Major Work

Signature was redacted for privacy.

Head of Major Department

Signature was redacted for privacy.

Dean of Graduate College

Iowa State University  
Of Science and Technology  
Ames, Iowa

1965

## TABLE OF CONTENTS

	page
I. INTRODUCTION	1
II. DEFINITIONS AND THEOREMS	2
A. Definitions	2
B. Theorems	7
III. NETWORK TRANSFORMATIONS	9
A. Derivation of the Star-Mesh Transformation	9
B. Derivation of a Cut-Set to Mesh Transformation	19
1. Transformations physically realizable with passive admittances	22
2. Transformations hypothetically realiz- able with mutual admittances	32
a. Relationship between node-pair and cut-set voltage variables	41
b. Cut-set matrices of oriented graphs	50
c. Successive transformations	54
IV. SUGGESTED RESEARCH PROBLEMS	68
V. SUMMARY	70
VI. BIBLIOGRAPHY	72
VII. ACKNOWLEDGEMENT	74

## I. INTRODUCTION

Network transformations have been used for many years as a tool in network analysis problems. One of the most familiar of network reduction techniques is the star-mesh transformation and a proof of this transformation by elementary network methods may be found in any basic electronics text such as Boast (1). A proof of this transformation will be developed in this thesis by linear graph theory in terms of the incidence matrix of the graph. A star-mesh transformation actually deletes one incidence set (one row of the incidence matrix  $A$  or one node of the network) of the defining matrix and the transformed graph is described by the new incidence matrix that is formed. Likewise, another transformation could logically be developed by the use of the more generalized cut-set matrix  $Q$  where a transformation would result in the deletion of one cut-set. If one row of an incidence matrix  $A$  is deleted the remaining matrix is still an incidence matrix. However, if one row of a cut-set matrix is deleted, the remaining rows do not necessarily define a cut-set matrix. Therefore, it will be necessary to determine conditions for the existence of a cut-set matrix after the deletion of a cut-set of edges.

This cut-set to mesh transformation which has been developed for use in topological analysis might possibly be extended to be of use in the synthesis of network problems.

## II. DEFINITIONS AND THEOREMS

This section contains a list of definitions and theorems that are necessary for understanding the development of the remaining sections. The definitions which are well standardized and the theorems for which proofs are not given may be found in the literature as indicated. The theorems for which proofs are given could not be found in the literature and are believed to be original.

## A. Definitions

1. A network element is any network component such as a resistor, capacitor, source, etc.
2. (13) An edge or element of a graph (the former will be used where possible so as to distinguish between the common usage of the word element in matrix theory) is a line segment together with its distinct endpoints.
3. (13) Associated with each network element are two real valued functions of bounded variation of the real variable  $t$ , an element voltage and an element current. The terms edge voltage and edge current of a graph will also be used to denote the element voltages and currents of the corresponding network elements.
4. (13) An oriented edge is an edge with orientation

shown by an arrowhead on the edge pointing away from the first vertex and toward the second vertex.

5. (13) A vertex is an end point of an edge. The word node is sometimes used for a vertex.
6. (13) A linear graph is a collection of edges, no two of which have a point in common that is not a vertex. Only graphs containing a finite number of edges will be considered.
7. (13) A graph in which every edge has been assigned an orientation is a directed graph.
8. (13) A subgraph is a subset of the edges of a graph and is therefore a graph.
9. (13) A graph  $G$  is connected if there exists a path between any two vertices of a graph.
10. (13) A graph  $G$  is nonseparable if every subgraph of  $G$  has at least two vertices in common with its complement. All other graphs are separable. A graph is separable if it consists of two subgraphs that are joined at only one vertex. In this paper a linear, directed, connected, nonseparable graph will be referred to simply as a graph  $G$ .
11. Two networks are equivalent networks if the voltage and current variables at the ports of interest are the same for both networks. There are many patterns of equivalence as shown by Reed (12) so it is

necessary to define equivalence as above for this development.

12. If two networks are equivalent then the graphs of these networks will be defined as equivalent graphs. This does not imply that the two graphs are the same.
13. (13) A vertex and an edge are incident with each other if the vertex is an endpoint of the edge.
14. (13) The degree of a vertex is the number of edges incident at the vertex.
15. A graph  $G$  with  $v$  vertices is a complete graph if each pair of vertices is connected by an edge (a series or parallel connection of edges is not allowed). An equivalent statement is that the degree of each vertex of a complete graph is  $v-1$  and no edges are in parallel or series. A complete graph has  $\frac{v(v-1)}{2}$  edges.
16. (13) The incidence or vertex matrix, denoted by  $A_a = [a_{ij}]$ , of a graph with  $v$  vertices and  $e$  edges, is the matrix with  $v$  rows and  $e$  columns. Each row corresponds to a vertex, and each column corresponds to an edge, such that
- $a_{ij} = 1$  if edge  $j$  is incident at node  $i$  and directed away from node  $i$ ,
- $a_{ij} = -1$  if edge  $j$  is incident at node  $i$ , and directed toward node  $i$ , and



$a_{ij} = 0$  if edge  $j$  is not incident at node  $i$ .

A matrix formed by removing one row from  $A_a$  will be labelled the incidence or vertex matrix  $A$ . The  $A$  matrix may contain at most two non-zero elements per column and if there are two non-zero elements in any column then one element must be a plus one and the other element a minus one.

17. (7) A maximally connected subgraph  $G_m$  of a graph  $G$  is a subgraph of  $G$  or the graph itself such that the addition of an edge in the complement of  $G_m$  to  $G_m$  makes the resultant subgraph no longer connected. If  $G$  is a connected non-separable graph, the maximally connected subgraph of  $G$  is the graph itself.
18. (13) The rank of a graph with  $v$  vertices and  $p$  maximal connected subgraphs is  $v-p$ . The rank of a connected non-separable graph is the same as the rank of  $A$  which is  $v-1$ .
19. (13) The nullity of a graph with  $e$  edges,  $v$  vertices, and  $p$  maximal connected subgraphs of  $\mu = e-v+p$ .
20. (13) A cut-set is a set of edges such that the removal of these edges from  $G$  reduces the rank of  $G$  by one, provided that no proper subset of this set reduces the rank of  $G$  by one when it is removed from  $G$ .
21. (13) The cut-set matrix, given by  $Q_a = [q_{ij}]$ , of a

graph with  $v$  vertices and  $e$  edges, is the matrix which has one row for each cut-set of the graph and  $e$  columns, such that

$q_{ij} = 1$  if edge  $j$  is in cut-set  $i$  and the orientations agree,

$q_{ij} = -1$  if edge  $j$  is in cut-set  $i$  and the orientations are opposite, and

$q_{ij} = 0$  if the edge  $j$  is not in cut-set  $i$ .

A matrix formed from  $v-1$  independent rows of  $Q_a$  will be labelled the cut-set matrix  $Q$ .

22. A complete incidence matrix is an incidence matrix  $A_a$  of a complete graph with  $v$  vertices and  $e$  edges.
23. (13) A tree is a connected subgraph of a connected graph which contains all the vertices of the graph but does not contain any closed paths (circuits).
24. (13) The fundamental system of cut-sets with respect to a tree is the set of  $v-1$  cut-sets, one for each branch, in which each cut-set includes exactly one branch of the tree. The fundamental matrix therefore contains a unit matrix as a submatrix.
25. A matrix  $A$  of order  $(m,n)$  is of maximum rank if the rank of  $A$  is  $m$  for  $m \leq n$  and  $n$  for  $n \leq m$ .
26. (5) A major determinant of a matrix is any determinant of maximum order of a matrix.
27. (5) A major determinant of the matrix  $A$  and a

major determinant of the matrix B are said to be corresponding majors of A and B only if the columns of A used to form the majors of A have the same indices as do the rows of B used to form the majors of B.

28. (13) If the current and voltages of an n-terminal network are written in the matrix form  $I = YV$ , where the voltages are with respect to an additional isolated node and the currents are directed into the terminals, then the matrix Y is termed the indefinite admittance matrix of the network. The sum of the elements in every row of Y is zero and the sum of the elements in every column of Y is zero. Huelsman (6) shows a proof of these conditions.

#### B. Theorems

Theorem 1 (5). If A is a matrix of order  $(m,n)$  and B is a matrix of order  $(n,m)$ , and if  $m \leq n$ , then  $\det AB$  is equal to the sum of the products of the corresponding majors of A and B.

Theorem 2 (2). If  $C'$  is the transpose of a square matrix C then  $\det C' = \det C$ .

Theorem 3. If A is a real  $m$  by  $n$  matrix ( $m \leq n$ ) which has rank  $m$ , then the rank of  $AA'$  is also  $m$ , so that  $AA'$  is a non-singular, symmetric matrix of order  $m$  with positive diagonal elements.

Proof. To prove the theorem, let us apply the Binet-Cauchy Theorem (Theorem 1) and write the  $\det AA'$  as the sum of the products of the corresponding minors,  $M_j$  of  $A$  and  $M'_j$  of  $A'$ . This result may be written as

$$\det (AA') = \sum_{j=1}^{\alpha} M_j M'_j \quad (1)$$

where  $\alpha = \binom{n}{m}$  ( $n$  columns,  $m$  at a time).

By Theorem 2,  $M_j = M'_j$  so Equation 1 may be written as

$$\det (AA') = \sum_{j=1}^{\alpha} (M_j)^2 \quad (2)$$

where all terms are non-negative and since  $A$  has rank  $m$  there must be at least one  $M_j$  of order  $m$  that is non zero so  $\det (AA') \neq 0$ , which proves that  $AA'$  is non-singular.

To prove that  $AA'$  is symmetric let

$$B = AA' \quad (3)$$

and show that  $B = B'$ . Take the transpose of both sides of Equation 3 and using the fact that  $(A')' = A$  we get

$$B' = (AA')' = AA' \quad (4)$$

which proves that  $AA'$  is symmetric. For a matrix  $A$  with real elements, each main diagonal element of  $AA'$  in the  $ii$  position is the sum of the squares of all  $n$  elements in the  $i$ th row of  $A$ , hence non-negative. The matrix  $A$  may not contain a row of zeroes since it has rank  $m$  so all diagonal elements of  $AA'$  must be positive.

### III. NETWORK TRANSFORMATIONS

#### A. Derivation of the Star-Mesh Transformation

For any electrical network  $N$  with corresponding graph  $G$  consisting of  $e$  edges and  $v$  vertices, Kirchhoff's current law may be written (13) as

$$Ai(t) = 0 \quad (5)$$

or

$$Qi(t) = 0 \quad (6)$$

where  $A$  and  $Q$  are the incidence and cut-set matrices respectively that were previously defined, and

$$i(t) = \begin{bmatrix} i_1(t) \\ i_2(t) \\ \vdots \\ i_e(t) \end{bmatrix} \quad (7)$$

where  $i_k(t)$  is the current associated with edge  $k$ .

Let us assume that all edges of the graph represent resistive elements of the network and that each current source  $j_k(t)$  has a shunt admittance  $y_k$  and the two network elements will be represented by one edge  $k$  with the reference convention as shown in Figure 1. Either  $y_k$  or  $j_k(t)$  may be zero. For convenience, let us assume that all voltage generators have a series impedance and will be transformed into an equivalent network as shown in Figure 1. This is not a restriction since a voltage source with no series impedance could easily be

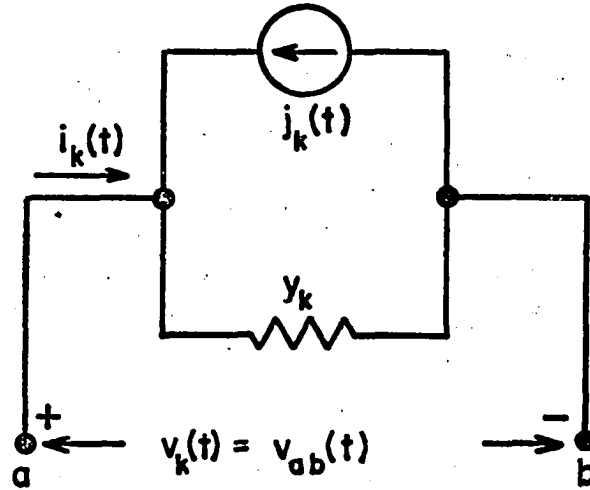
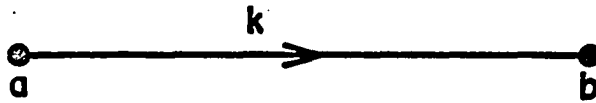
(a) Network element  $k$ (b) Edge  $k$ Figure 1. Current and voltage convention for an edge  $k$

handled by the Blakesley E-shift as described by Reed (11). All parallel network elements will be combined and considered as one edge.

Letting capital letters correspond to Laplace-transformed quantities, the edge currents may be expressed as

$$I = YV - J \quad (8)$$

where the edge voltages are

$$V = \begin{bmatrix} V_1 \\ V_2 \\ \vdots \\ V_e \end{bmatrix}, \quad (9)$$

Y is the diagonal admittance matrix of e diagonal elements, and the current sources are

$$J = \begin{bmatrix} J_1 \\ J_2 \\ \vdots \\ J_e \end{bmatrix}. \quad (10)$$

The edge voltages V are related (13) to the node voltages (also called node-datum voltages)  $V_n$  by

$$V = A'V_n \quad (11)$$

where

$$V_n = \begin{bmatrix} V_{1d} \\ V_{2d} \\ \vdots \\ V_{\rho d} \end{bmatrix}, \quad \rho = v-1, \quad (12)$$

$A'$  is the transpose of  $A$ , and  $V_{kd}$  is the voltage of node  $k$  with respect to the reference or datum node  $d$ . If Equation 11 is substituted into Equation 8 and the result multiplied by  $A$ , then

$$AI = AYA'V_n - AJ \quad (13)$$

and since  $AI = 0$  from Equation 5 we get

$$AJ = AYA'V_n \quad (14)$$

The left side of Equation 14 is a column matrix of source currents associated with each vertex or node and will be called the node currents  $I_n$  so Equation 14 may be written as

$$I_n = AYA'V_n \quad (15)$$

Equation 15 can be written in partitioned form as

$$\begin{bmatrix} I_{x_n} \\ \text{---} \\ 0 \end{bmatrix} = \begin{bmatrix} A_x \\ \text{---} \\ A_y \end{bmatrix} Y \begin{bmatrix} A'_x \\ \text{---} \\ A'_y \end{bmatrix} \begin{bmatrix} V_{x_n} \\ \text{---} \\ V_{y_n} \end{bmatrix} \quad (16)$$

where  $A_y$  represents those vertices that are not incident to a source edge (edge representing a source as illustrated in Figure 1),  $V_{y_n}$  represents the corresponding node voltages, and  $A_x$  represents the remaining incidence sets of  $A$  with corresponding node currents  $I_{x_n}$  and node voltages  $V_{x_n}$ .

Equation 16 may be arranged as

$$\begin{bmatrix} I_{x_n} \\ \text{---} \\ 0 \end{bmatrix} = \begin{bmatrix} A_x YA'_x & \text{---} & A_x YA'_y \\ \text{---} & \text{---} & \text{---} \\ A_y YA'_x & \text{---} & A_y YA'_y \end{bmatrix} \begin{bmatrix} V_{x_n} \\ \text{---} \\ V_{y_n} \end{bmatrix} \quad (17)$$

or in terms of two equations





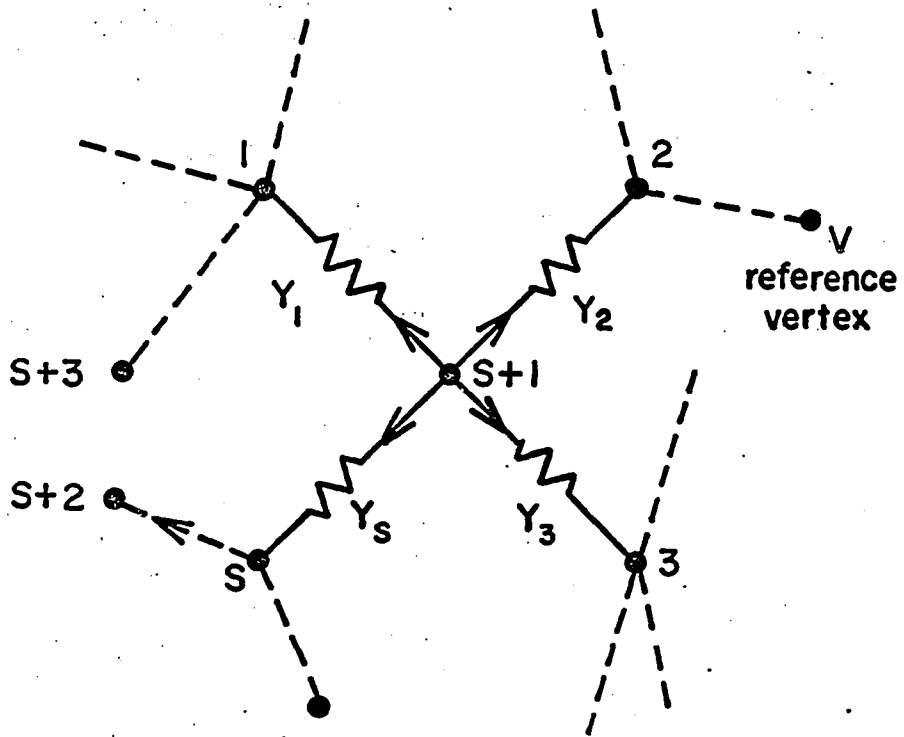

Figure 2. Star network imbedded in a network  $N$  with  $s$  admittances incident to vertex  $s+1$

vertices 1, 2, ..., s+1, then  $(A_x)_{11} = 0$  and with orientations as shown in Figure 2 the submatrix  $(A_x)_{21}$  becomes a negative unit matrix and the submatrix  $A_y$  contains plus ones in the first s columns followed by zeroes in the remaining columns of A.

The diagonal element admittance matrix of the network is

$$Y = \left[ \begin{array}{ccc|ccc} Y_1 & & & & & \\ & Y_2 & & & & \\ & \dots & \dots & & & \\ & & Y_s & & & \\ \hline & & & Y_{s+1} & & \\ & & & & Y_{s+2} & \\ & 0 & & & \dots & \\ & & & & & Y_e \end{array} \right] \quad (22)$$

and the term

$$A_y Y A_y' = \sum_{i=1}^s Y_i = \Sigma Y_i \quad (23)$$

which is certainly not zero so its inverse exists and

$$Y A_y' (A_y Y A_y')^{-1} A_y Y = \frac{1}{\Sigma Y_i} \left[ \begin{array}{cccc|c} Y_1^2 & Y_1 Y_2 & Y_1 Y_3 & \dots & Y_1 Y_s & \\ Y_2 Y_1 & Y_2^2 & Y_2 Y_3 & \dots & Y_2 Y_s & \\ \dots & \dots & \dots & \dots & \dots & \\ Y_s Y_1 & Y_s Y_2 & Y_s Y_3 & \dots & Y_s^2 & \\ \hline & & & & & 0 \end{array} \right] \quad (24)$$

Let the bracketed term of Equation 20 be called  $Y_y$  for simplicity such that

$$Y_y = Y - Y A_y' (A_y Y A_y')^{-1} A_y Y \quad (25)$$

and the result is

$$Y_y = \left[ \begin{array}{ccc|ccc}
 \frac{(Y_1 \sum_{i=2}^s Y_i)}{\sum Y_i} & \frac{-Y_1 Y_2}{\sum Y_i} & \dots & \frac{-Y_1 Y_s}{\sum Y_i} & & \\
 \frac{-Y_2 Y_1}{\sum Y_i} & \frac{Y_2 (Y_1 + \sum_{i=3}^s Y_i)}{\sum Y_i} & \dots & \frac{-Y_2 Y_s}{\sum Y_i} & 0 & \\
 \dots & \dots & \dots & \dots & \dots & \\
 \frac{-Y_s Y_1}{\sum Y_i} & \frac{-Y_s Y_2}{\sum Y_i} & \dots & \frac{Y_s \sum_{i=1}^s Y_i}{\sum Y_i} & & \\
 \hline
 & 0 & & & Y_{s+1} & \\
 & & & & Y_{s+2} & \\
 & & & & \dots & \\
 & & & & & Y_e
 \end{array} \right] \quad (26)$$

The congruence of  $Y_y$  may be formed as

$$Y_y = H Y_d H' \quad (27)$$

where  $Y_d$  is a diagonal matrix of  $\binom{s}{2} + e - s$  elements, where the  $s$  edges incident to vertex  $s+1$  have been replaced by  $\binom{s}{2}$  ( $s$  things taken 2 at a time) transformed edges and the remaining edges not incident to vertex  $s+1$  are the same. The  $\binom{s}{2}$  transformed edges are the combinations of the products of  $s$  admittances taken two at a time divided by the sum of the  $s$  admittances. The negative of these terms are those terms below the major diagonal of  $Y_y$  in Equation 26 and are arranged as

$$\begin{array}{c}
 \begin{array}{cccccccc}
 & 12 \dots & 1s & 23 \dots & 2s \dots & \beta s & s+1 & s+2 \dots e \\
 12 & Y_{12} & & & & & & & \\
 \vdots & \cdot & & & & & & & \\
 \vdots & \cdot & & & & & & & \\
 1s & & Y_{1s} & & 0 & & & 0 & \\
 23 & & & Y_{23} & & & & & \\
 \vdots & & & \cdot & & & & & \\
 \vdots & & & \cdot & & & & & \\
 2s & & 0 & & Y_{2s} & & & & \\
 \vdots & & & & \cdot & & & & \\
 \vdots & & & & \cdot & & & & \\
 \beta s & & & & & Y_{\beta s} & & & \\
 \hline
 s+1 & & & & & & Y_{s+1} & & \\
 s+2 & & & & & & & Y_{s+2} & 0 \\
 \vdots & & & 0 & & & & 0 & \cdot \\
 \vdots & & & & & & & & \cdot \\
 \vdots & & & & & & & & \cdot \\
 e & & & & & & & & Y_e
 \end{array}
 \end{array}
 \quad (28)$$

where  $\beta = s-1$ ,

$$Y_{12} = \frac{Y_1 Y_2}{\sum Y_i} \quad (29)$$

and likewise for the other diagonal elements of  $Y_d$ .

The matrix  $H$  may be partitioned as

$$H = \left[ \begin{array}{c|c}
 H_{11} & 0 \\
 \hline
 0 & U
 \end{array} \right] \quad (30)$$

where  $H_{11}$  may be written as

$$H_{11} = \begin{matrix} & 12 & 13 & \dots & 1s & 23 & \dots & 2s & 34 & \dots & 3s & \dots & \beta s \\ \begin{matrix} 1 \\ 2 \\ 3 \\ \vdots \\ s \end{matrix} & \left[ \begin{array}{cccccccccccc} 1 & & & & & & & & & & & & & \\ & 1 & 1 & 1 & 1 & & & & & & & & & \\ & -1 & & & & & 1 & 1 & 1 & 1 & & & & \\ & & -1 & & & & -1 & & & & 1 & 1 & 1 & 1 & \\ & & & \dots & \dots & \dots & \dots & \dots & \dots & \dots & & & & & \\ & & & & -1 & & & -1 & & & & -1 & & & -1 \end{array} \right] \end{matrix} \quad (31)$$

where only the non-zero terms have been shown. The columns are numbered to correspond to the double subscript notation appearing in  $(Y_d)_{11}$ .

The matrix  $H_{11}$  may be formed by placing, in any column  $bc$  ( $b < c$ ), a plus one in row  $b$  and a minus one in row  $c$ . Therefore,  $H_{11}$  becomes a complete incidence matrix.

Equation 20 may now be written as

$$I_{x_n} = A_x H Y_d H' A_x' V_{x_n} \quad (32)$$

or

$$I_{x_n} = (A_x H) Y_d (A_x H)' V_{x_n} \quad (33)$$

since  $(A_x H)' = H' A_x'$ .

Equation 33 has the same form as Equation 15. Therefore, if  $A_x H$  is an incidence matrix then there is a corresponding graph  $G_3$  with  $v-1$  vertices and  $e + \binom{s}{2} - s$  edges which is equivalent to the original graph  $G$ . The rank of  $G$  is  $v-1$  and the nullity of  $G$  is  $\mu = e - v + 1$ . The rank of  $G_3$  is  $v-2$  and its nullity is  $\mu_3 = e + \binom{s}{2} - s - (v-1) + 1$ . Therefore, in the equivalent graph the rank has been reduced by one and the

nullity has been increased by  $\binom{s}{2} - s + 1$ . When  $s = 3$  the rank has been reduced by one and the nullity has been increased by one. For  $s > 3$ , the nullity has increased by a greater amount than the rank has decreased.

If  $A_x H$  is written in partitioned form as

$$A_x H = \begin{bmatrix} 0 & | & (A_x)_{12} \\ \hline -U & | & (A_x)_{22} \end{bmatrix} \begin{bmatrix} H_{11} & | & 0 \\ \hline 0 & | & U \end{bmatrix} = \begin{bmatrix} 0 & | & (A_x)_{12} \\ \hline -H_{11} & | & (A_x)_{22} \end{bmatrix}, \quad (34)$$

then it is obvious that since  $-H_{11}$  is an incidence matrix and the remaining columns are the same as the  $e$ - $s$  columns of  $A$ ,  $A_x H$  is also an incidence matrix. Therefore  $A_x H$  describes an equivalent network where vertex  $s+1$  has been deleted and network elements  $1, 2, \dots, s$  have been replaced by transformed elements connected between each pair of vertices  $1, 2, \dots, s$ . The element admittance matrix for the equivalent network is given by Equation 28. This completes the derivation of the star-mesh transformation which is illustrated in Figure 3.

#### B. Derivation of a Cut-Set to Mesh Transformation

This development will follow the pattern of the previous development except the cut-set matrix  $Q$  will be used to define the graph rather than the incidence matrix  $A$ . This is more general since an incidence set is also a cut-set but the converse is not true.

The edge voltages  $V$  are related to the cut-set voltage variables  $V_q$  as

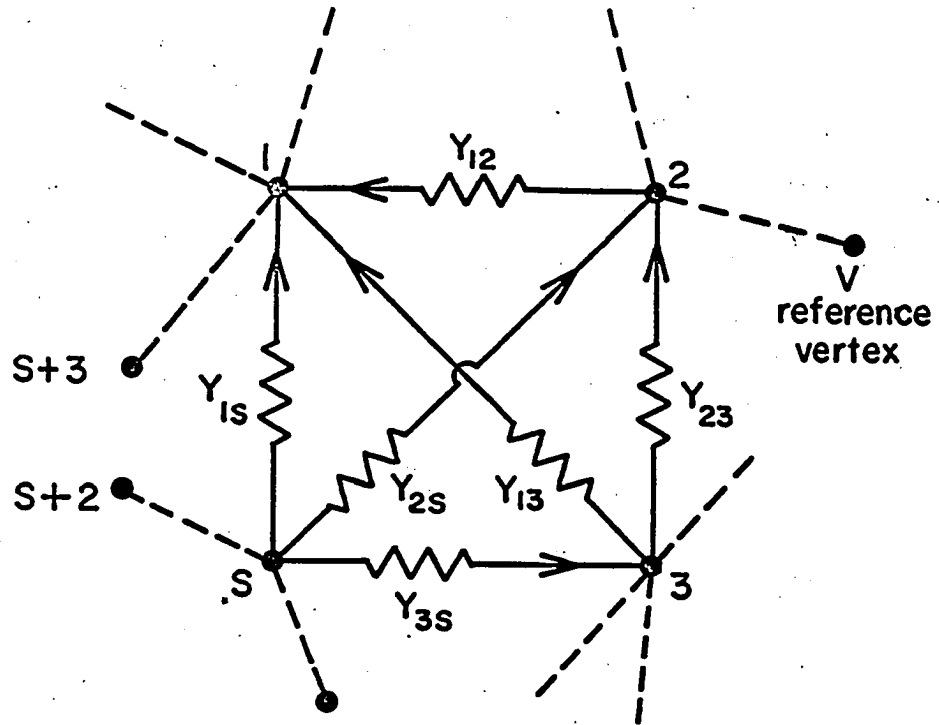

Figure 3. Mesh network, equivalent to star network of Figure 2



$$V = Q' V_q \quad (35)$$

where

$$V_q = \begin{bmatrix} V_{q1} \\ V_{q2} \\ \vdots \\ V_{qp} \end{bmatrix}, \quad p = v-1, \quad (36)$$

and  $V_{qk}$  is the voltage variable of cut-set  $k$ . If Equation 35 is now substituted into Equation 8 and the result multiplied by  $Q$ , then

$$QI = QYQ'V_q - QJ \quad (37)$$

and since  $QI = 0$ , the result is

$$QJ = QYQ'V_q. \quad (38)$$

The left side of Equation 38 is a column matrix of source currents associated with each cut-set of the network and will be labelled  $I_q$ , so Equation 38 may be written as

$$I_q = QYQ'V_q. \quad (39)$$

Equation 39 may be partitioned such that

$$\begin{bmatrix} I_{xq} \\ 0 \end{bmatrix} = \begin{bmatrix} Q_x \\ Q_y \end{bmatrix} Y \begin{bmatrix} Q'_x & Q'_y \end{bmatrix} \begin{bmatrix} V_{xq} \\ V_{yq} \end{bmatrix} \quad (40)$$

where  $Q_y$  represents cut-sets which do not contain sources and  $V_{yq}$  represents the corresponding cut-set voltages. The submatrix  $Q_x$  is the remaining cut-sets of  $Q$  with  $I_{xq}$  and  $V_{xq}$  representing the corresponding cut-set currents and

remaining cut-set voltages. Using the same procedure as was used to derive Equation 20, we get as an equivalent equation,

$$I_{x_q} = Q_x [Y - YQ_y'(Q_y YQ_y')^{-1} Q_y Y] Q_x' V_{x_q} \quad (41)$$

If a network may be realized that is described by Equation 41 then we have found a transformation as in Section A but instead of replacing a star by a mesh we will replace a cut-set by a mesh. The first case to be investigated will be a transformation physically realizable with passive network elements (i.e., positive-valued elements).

1. Transformations physically realizable with passive admittances

Now consider a graph  $G$  of  $v$  vertices and  $e$  edges as illustrated in Figure 4 which is divided into two subgraphs  $G_1$  and  $G_2$ , connected by the cut-set  $C = c_1, c_2, \dots, c_s$  which contains no sources. Let  $w_n$  be the vertices of  $G_1$  where  $n$  of these vertices are incident to the edges of  $C$  and  $u_m$  be the vertices of  $G_2$  where  $m$  of these vertices are incident to the edges of  $C$ . The remaining  $e-s$  edges are indicated by the dotted lines. We will choose  $n-2$  cut-sets which will be  $n-1$  incidence sets of  $G_1$  and  $m-1$  incidence sets of  $G_2$  and for convenience let the two vertices that are deleted from  $A_a$  be  $w_1$  and  $u_k$  (one reference vertex on each side of  $C$ , incident to an edge or edges of  $C$ ). Then since

$$n + m = v \quad (42)$$



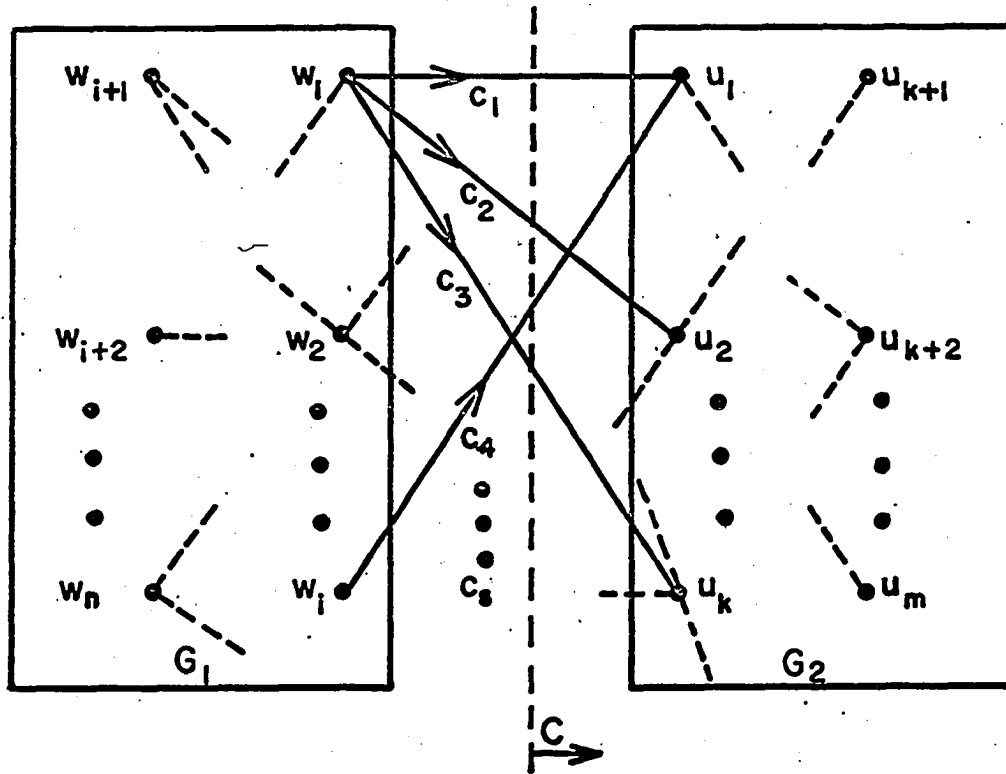

Figure 4. Connected non-separable graph  $G$  of  $v$  vertices and  $e$  edges, with subgraphs  $G_1$  and  $G_2$  connected by the edges of the cut-set  $C$

of cut-set C. Likewise, the non-zero elements of rows  $w_1$  through  $w_{1-1}$  of  $(Q_x)_{21}$  are positive since each edge of C is oriented away from these vertices and the non-zero elements of rows  $u_1$  through  $u_{k-1}$  of  $(Q_x)_{21}$  are negative since each edge of C is oriented toward these vertices.

Since  $A_y$  and  $Q_y$  are identical, the term of Equation 41 in the brackets is equal to  $Y_y$  of Equation 27 so Equation 41 may be written as

$$I_{x_q} = Q_x H Y_d (Q_x H)' V_{x_q} \quad (44)$$

It is now necessary to determine when  $Q_x H$  is a cut-set matrix. Since (13)

$$Q = DA, \quad (45)$$

where D is a non-singular transformation, then if  $Q_x H$  is an incidence matrix it is also a cut-set matrix.

If  $Q_x H$  is written in partitioned form as

$$Q_x H = \left[ \begin{array}{c|c} 0 & (Q_x)_{12} \\ \hline (Q_x)_{21} H_{11} & (Q_x)_{22} \end{array} \right] \quad (46)$$

and since the e-s columns (e-s edges not in cut-set C) of  $Q_x H$  are the same as the corresponding columns of  $Q_x$ , then if the matrix  $(Q_x)_{21} H_{11}$  is (is not) an incidence matrix then  $Q_x H$  is (is not) an incidence matrix.

With these elementary remarks, the following theorem may be stated.

Theorem 4. The matrix  $Q_x H$  is an incidence matrix if

and only if the submatrix  $(Q_x)_{21}$  does not contain an S submatrix where

$$S = \begin{bmatrix} 1 & 0 \\ 0 & -1 \end{bmatrix} \quad (47)$$

Proof: The sufficiency of the above theorem may be shown by assuming that  $Q_x H$  is not an incidence matrix and proving that  $(Q_x)_{21}$  contains at least one S submatrix. If  $(Q_x)_{21} H_{11}$  is not an incidence matrix, then there is at least one column ab (the double subscript notation refers to the column designations given to  $H_{11}$  in Equation 31) of  $(Q_x)_{21} H_{11}$  that contains at least two plus ones or two minus ones in two rows c and d of  $(Q_x)_{21} H_{11}$ . Each row of  $(Q_x)_{21} H_{11}$  represents the sum or minus the sum of n rows of  $H_{11}$  where n is the number of non-zero terms in the corresponding row of  $(Q_x)_{21}$ . For a plus one to appear in any row of  $(Q_x)_{21} H_{11}$  there must be at most s-1 non-zero terms in the corresponding row of  $(Q_x)_{21}$ . If there are s non-zero terms in any row of  $(Q_x)_{21}$  then the corresponding row of  $(Q_x)_{21} H_{11}$  will be a row of zeroes since  $H_{11}$  is a complete incidence matrix. In column ab of  $H_{11}$  a plus one appears in row a and a minus one appears in row b for  $a < b$ . For a plus (or minus) one to appear in row c column ab of  $(Q_x)_{21} H_{11}$ , there must be in row c of  $(Q_x)_{21}$  a plus (minus) one in column a or a minus (plus) one in column b but not both. For a plus (or minus) one to appear in row d column ab of  $(Q_x)_{21} H_{11}$  there must be in row d of

$(Q_x)_{21}$  a plus (minus) one in column a or a minus (plus) one in column b, but not both. Since  $(Q_x)_{21}$  is an incidence set, column ab may not have a plus (or minus) one in both row c and d. Therefore, an S submatrix exists in  $(Q_x)_{21}$ .

For the other part of the proof, assume that an S submatrix appears in rows c and d and columns a and b of  $(Q_x)_{21}$ . Since  $H_{11}$  is a complete incidence matrix with  $\binom{S}{2}$  independent columns, there are two rows a and b of  $H_{11}$  which have two non-zero elements in column ab, one element being a plus one and the other element being a minus one. Therefore, in column ab of  $(Q_x)_{21}H_{11}$  two plus ones or two minus ones will appear in rows c and d. Hence  $(Q_x)_{21}H_{11}$  or likewise  $Q_x H$  is not an incidence matrix. This completes the proof of the theorem.

In terms of the edges of C, no transformation will exist if one edge of C, say  $c_a$ , is incident to vertex  $w_a$  of  $G_1$  but not incident to vertex  $u_b$  of  $G_2$  and another edge  $c_b$  is incident to  $u_b$  but not  $w_a$ . Neither of the vertices  $u_b$  and  $w_b$  may be the reference vertices that were chosen.

As an example, let us choose the network N composed of networks  $N_1$  and  $N_2$  connected by edges one through four as is illustrated in Figure 5a. With  $w_2$  and  $u_3$  chosen as the reference nodes,  $(Q_x)_{21}$  may be written as,

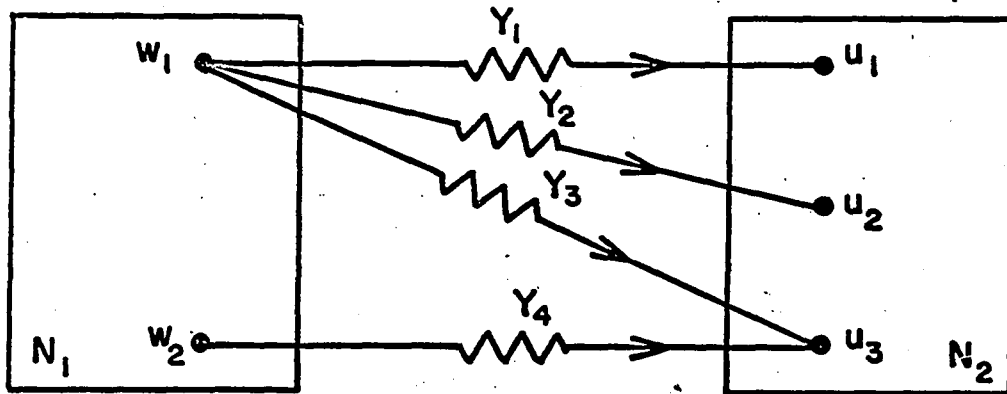

(a) Network N

(b) Network  $N_3$ 

Figure 5. A network N and its equivalent transformed network  $N_3$



$$(Q_x)_{21} = \begin{matrix} & \begin{matrix} 1 & 2 & 3 & 4 \end{matrix} \\ \begin{matrix} w_1 \\ u_1 \\ u_2 \end{matrix} & \begin{bmatrix} 1 & 1 & 1 & 0 \\ -1 & 0 & 0 & 0 \\ 0 & -1 & 0 & 0 \end{bmatrix} \end{matrix} \quad (48)$$

and since  $(Q_x)_{21}$  does not contain an S submatrix then  $Q_x H$  is an incidence matrix.

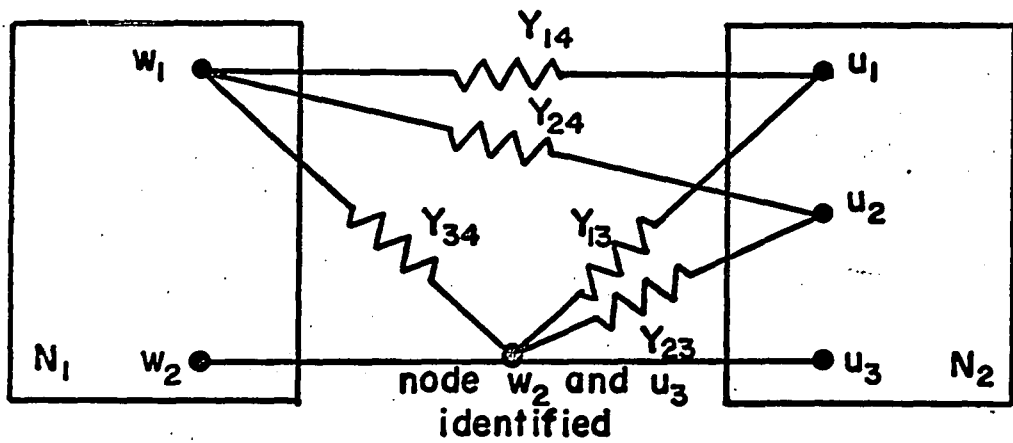
The product  $(Q_x)_{21} H_{11}$  now becomes

$$(Q_x)_{21} H_{11} = \begin{matrix} & \begin{matrix} 12 & 13 & 14 & 23 & 24 & 34 \end{matrix} \\ \begin{matrix} w_1 \\ u_1 \\ u_2 \end{matrix} & \begin{bmatrix} 0 & 0 & 1 & 0 & 1 & 1 \\ -1 & -1 & -1 & 0 & 0 & 0 \\ 1 & 0 & 0 & -1 & -1 & 0 \end{bmatrix} \end{matrix} \quad (49)$$

and the network of the transformed graph represented by the incidence matrix of Equation 49 is illustrated in Figure 5b.

The admittances  $Y_{12}$ ,  $Y_{13}$ , etc. in Figure 5b are

$$Y_{12} = \frac{Y_1 Y_2}{Y_1 + Y_2 + Y_3 + Y_4}, \quad Y_{13} = \frac{Y_1 Y_3}{Y_1 + Y_2 + Y_3 + Y_4} \quad (50)$$

and likewise for the other edges.

Some other transformations are illustrated in Figure 6.

It is common knowledge that if two 2-terminal networks  $N_1$  and  $N_2$  with terminals 1 and 2 are connected at terminals 1 by  $Y_1$  and at terminals 2 by  $Y_2$ , then an equivalent network is one with admittance  $\frac{Y_1 Y_2}{Y_1 + Y_2}$  between terminals number 1 of

both networks and the number 2 terminals shorted together.

This equivalent network is shown in Figure 6a. This method

	NETWORK	EQUIVALENT TRANSFORMED NETWORK
a		
b		
c		
d		
e		

Figure 6. Networks and their equivalents

presents a proof of this rather obvious transformation. The equivalent networks of Figure 6c and 6d are networks where network  $N_1$  contains only one vertex  $w_1$ . These transformations are the familiar star-mesh transformations which were derived previously. If the network is separable at vertex  $w_1$  then  $N_1$  may contain vertices other than  $w_1$  and the star-mesh transformation may still be used after the network is separated.

Theorem 4 gives the necessary and sufficient conditions for  $Q_x H$  to be an incidence matrix in terms of the edges of the cut-set involved. It was originally believed that the conditions, for  $Q_x H$  to be a cut-set matrix, could be determined solely by the edges of  $C$ , independent of the remainder of the graph, but such is not the case. This will not be pursued further since Gould (3), Tutte (15), Lofgren (8), and Mayeda (9) have presented methods for determining whether a matrix is a cut-set matrix of a nonoriented graph and recently Mayeda (10) has modified his method to include the necessary and sufficient conditions for a matrix to be a fundamental cut-set matrix of an oriented graph.

A more general approach will now be taken where the congruence of  $Y_y$  will not be formed and it will become necessary to determine when a general  $Q_x$  (not necessarily restricted to incidence sets as was done in Section IIIB1) is still a cut-set matrix.

## 2. Transformations hypothetically realizable with mutual admittances

A cut-set to mesh transformation hypothetically realizable with mutual coupling between edges can be found for a more general class of networks than those already discussed.

For this derivation, the bracketed term of Equation 41 labelled  $Y_y$  will not be reduced to a diagonal admittance matrix as was done previously. The admittance matrix  $Y_y$  will be hypothetically realized with self admittances represented by the diagonal terms and mutual admittances represented by the off diagonal terms and with a configuration corresponding to the graph of the cut-set matrix  $Q_x$ . It now becomes necessary to find the conditions under which  $Q_x$  is a cut-set matrix.

If Equation 11 is equated to Equation 35 as

$$Q'V_q = A'V_n \quad (51)$$

and if the transpose of  $Q$  from Equation 45 is substituted into Equation 51, the result is

$$A'D'V_q = A'V_n \quad (52)$$

In general, we cannot assume by the conditions of Equation 52 that  $D'V_q = V_n$  but, since  $A$  satisfies the conditions of Theorem 3, both sides of Equation 52 may be multiplied by  $(AA')^{-1}A$ . Using the result that  $(AA')^{-1}(AA') = U$  we get

$$V_n = D'V_q \quad (53)$$

This now leads us to the following theorem.

Theorem 5. Given a graph with  $v$  vertices and a cut-set matrix  $Q$ , if any  $i$  number of cut-sets (rows)  $Q_i$  ( $0 < i < v-1$ ) are deleted from  $Q$ , then the remaining  $(v-1)-i$  rows form a cut-set matrix  $Q_{-i}$  if the voltage variables of the  $i$  cut-sets  $V_{q_i}$  are a linear independent combination of  $i$  node-datum voltage variables  $V_{id}$ .

Proof: Assume that the  $i$  node-datum voltage variables  $V_{id}$  are related to the  $i$  cut-set voltages  $V_{q_i}$  as

$$V_{id} = D_{22}' V_{q_i} \quad (54)$$

where  $D_{22}'$  is non-singular. It is then possible to write

Equation 53 in partitioned form thus:

$$\begin{bmatrix} V_{1d} \\ V_{2d} \\ \vdots \\ V_{\alpha d} \\ \hline V_{id} \end{bmatrix} = \begin{bmatrix} & | & \\ \hline D_{11}' & | & D_{21}' \\ \hline 0 & | & D_{22}' \end{bmatrix} \begin{bmatrix} V_{q_1} \\ V_{q_2} \\ \vdots \\ V_{q_\alpha} \\ \hline V_{q_i} \end{bmatrix} \quad (55)$$

where  $\alpha = p-i = v-1-i$ . Since  $D'$  is non-singular and has rank  $v-1$ , the  $D_{11}'$  must be non-singular. Equation 45 may now be written in partitioned form as

$$\begin{bmatrix} Q_{-i} \\ \hline Q_i \end{bmatrix} = \begin{bmatrix} D_{11}' & | & 0 \\ \hline D_{21}' & | & D_{22}' \end{bmatrix} \begin{bmatrix} A_{-i} \\ \hline A_i \end{bmatrix} \quad (56)$$

where  $A_i$  is a matrix formed from  $i$  rows of  $A$  and  $A_{-i}$  is the matrix  $A$  with  $i$  rows deleted. Therefore,

$$Q_{-i} = D_{11}A_{-i} \quad (57)$$

and, since  $A_{-i}$  is an incidence matrix and  $D_{11}$  is non-singular,  $Q_{-i}$  is a cut-set matrix. This completes the proof which gives the sufficient conditions for  $Q_{-i}$  to be a cut-set matrix and hence the existence of a cut-set to mesh transformation.

As a special case of the above theorem for  $i = 1$  (one row deleted),  $Q_{-1}$  is a cut-set matrix if  $V_{q_1}$  is a node-pair voltage (a voltage between a pair of nodes). For this case the term node-pair voltage may be more appropriate.

The conditions of Theorem 5 are not necessary conditions for  $Q_{-i}$  to be a cut-set matrix as is illustrated by the following example.

Given the graph of Figure 7 with  $v-1$  independent cut-sets shown as dotted lines, then  $Q$  becomes

$$Q = \begin{matrix} & \begin{matrix} 1 & 2 & 3 & 4 & 5 & 6 & 7 & 8 & 9 \end{matrix} \\ \begin{matrix} 1 \\ 2 \\ 3 \\ 4 \\ 5 \end{matrix} & \left[ \begin{array}{ccccccccc} 1 & 0 & 1 & 0 & 0 & 1 & -1 & 1 & 0 \\ 0 & -1 & 0 & 0 & 0 & 0 & 0 & -1 & 1 \\ 0 & 0 & 1 & 0 & -1 & 0 & -1 & 1 & 0 \\ 0 & 0 & 0 & -1 & -1 & -1 & 0 & 0 & 0 \\ 0 & 0 & 0 & 0 & 0 & -1 & 1 & -1 & 1 \end{array} \right] \end{matrix} \quad (58)$$

If the incidence matrix is chosen as the incidence sets for vertices 1, 2, 3, 4 and 5 (vertex 6 is chosen as the reference vertex) then

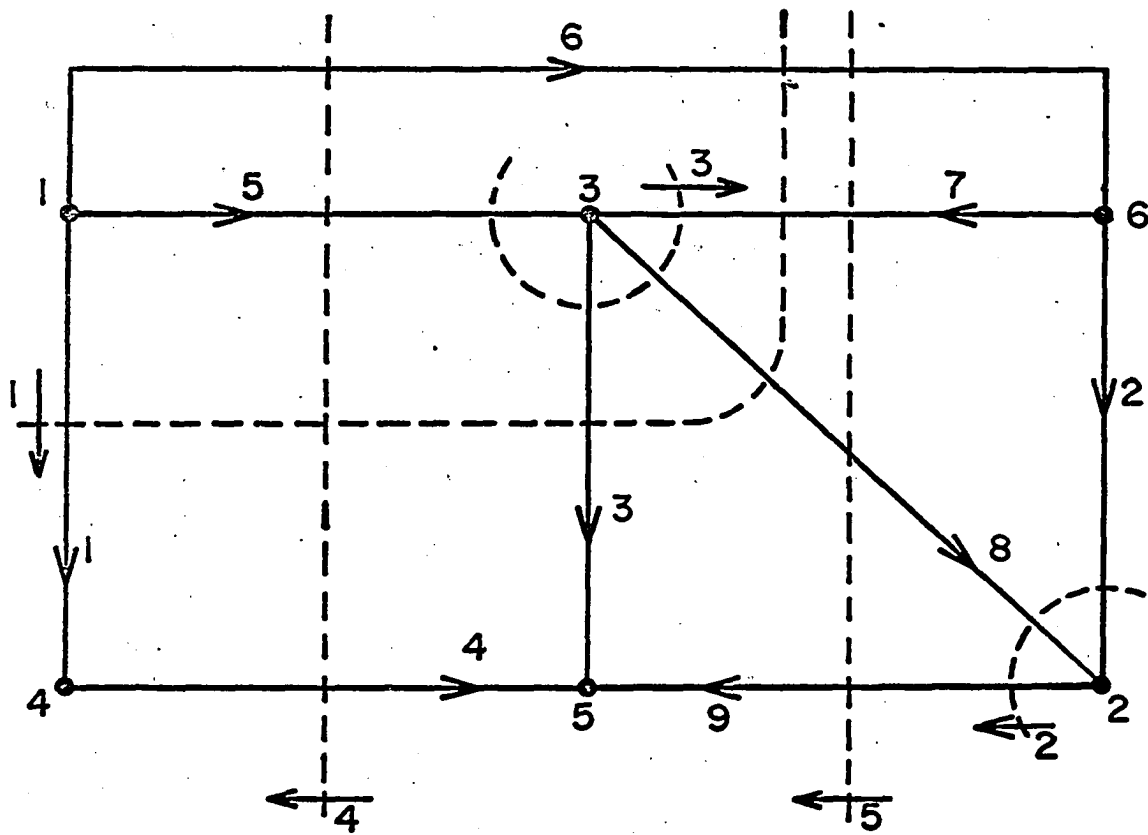

Figure 7. Graph with cut-sets shown as dotted lines

$$A = \begin{matrix} & \begin{matrix} 1 & 2 & 3 & 4 & 5 & 6 & 7 & 8 & 9 \end{matrix} \\ \begin{matrix} 1 \\ 2 \\ 3 \\ 4 \\ 5 \end{matrix} & \left[ \begin{array}{ccccccccc} 1 & 0 & 0 & 0 & 1 & 1 & 0 & 0 & 0 \\ 0 & -1 & 0 & 0 & 0 & 0 & 0 & -1 & 1 \\ 0 & 0 & 1 & 0 & -1 & 0 & -1 & 1 & 0 \\ -1 & 0 & 0 & 1 & 0 & 0 & 0 & 0 & 0 \\ 0 & 0 & -1 & -1 & 0 & 0 & 0 & 0 & -1 \end{array} \right] \end{matrix} \quad (59)$$

and the non-singular transformation D relating Q and A  
( $Q = DA$ ) becomes

$$D = \begin{matrix} & \begin{matrix} 1 & 2 & 3 & 4 & 5 \end{matrix} \\ \begin{matrix} 1 \\ 2 \\ 3 \\ 4 \\ 5 \end{matrix} & \left[ \begin{array}{ccccc} 1 & 0 & 1 & 0 & 0 \\ 0 & 1 & 0 & 0 & 0 \\ 0 & 0 & 1 & 0 & 0 \\ -1 & 0 & 0 & -1 & 0 \\ \hline -1 & 0 & -1 & -1 & -1 \end{array} \right] \end{matrix} \quad (60)$$

and

$$D' = \begin{matrix} & \begin{matrix} 1 & 2 & 3 & 4 & 5 \end{matrix} \\ \begin{matrix} 1 \\ 2 \\ 3 \\ 4 \\ 5 \end{matrix} & \left[ \begin{array}{ccccc} 1 & 0 & 0 & -1 & -1 \\ 0 & 1 & 0 & 0 & 0 \\ 1 & 0 & 1 & 0 & -1 \\ 0 & 0 & 0 & -1 & -1 \\ 0 & 0 & 0 & 0 & -1 \end{array} \right] \end{matrix} \quad (61)$$

If we substitute Equation 61 into Equation 53 and solve for  $V_q$  the results are

$$V_{q_1} = V_{16} - V_{46} = V_{14}, \quad (62a)$$

$$V_{q_2} = V_{26}, \quad (62b)$$

$$V_{q_3} = -V_{16} + V_{36} + V_{46} - V_{56} = V_{45} - V_{13}, \quad (62c)$$

$$V_{q_4} = -V_{46} + V_{56} = V_{54}, \quad (62d)$$

and

$$V_{q_5} = -V_{56} = V_{65}. \quad (62e)$$

Therefore, the voltage variables of  $q_1$ ,  $q_2$ ,  $q_4$ , and  $q_5$  are node-pair voltage variables but the voltage variable of cut-set 3 is a combination of node-pair voltages.



To demonstrate the use of Theorem 5, let us delete row 5 from  $Q$  and the result is

$$Q_{-5} = \begin{matrix} & \begin{matrix} 1 & 2 & 3 & 4 & 5 & 6 & 7 & 8 & 9 \end{matrix} \\ \begin{matrix} 1 \\ 2 \\ 3 \\ 4 \end{matrix} & \begin{bmatrix} 1 & 0 & 1 & 0 & 0 & 1 & -1 & 1 & 0 \\ 0 & -1 & 0 & 0 & 0 & 0 & 0 & -1 & 1 \\ 0 & 0 & 1 & 0 & -1 & 0 & -1 & 1 & 0 \\ 0 & 0 & 0 & -1 & -1 & -1 & 0 & 0 & 0 \end{bmatrix} \end{matrix}, \quad (63)$$

which is a cut-set matrix since, from the partitioned form of Equation 60,

$$Q_{-5} = \begin{matrix} & \begin{matrix} 1 & 2 & 3 & 4 \end{matrix} \\ \begin{matrix} 1 \\ 2 \\ 3 \\ 4 \end{matrix} & \begin{bmatrix} 1 & 0 & 1 & 0 \\ 0 & 1 & 0 & 0 \\ 0 & 0 & 1 & 0 \\ -1 & 0 & 0 & -1 \end{bmatrix} \end{matrix} A_{-5} \quad (64)$$

where  $A_{-5}$  is the  $A$  matrix of Equation 59 with row and column ordering preserved and row 5 deleted. The graph represented by Equation 63 is illustrated in Figure 8, where the edges shown by heavy lines represent those edges that have been transformed (values changed) and are mutually coupled. The voltage variable of cut-set 5 was the voltage  $V_{65}$  as given by Equation 62e, so these two vertices are identified or coalesced. If an edge had been present between these vertices then a self loop would be present at these vertices in the graph of Figure 8. The element admittance matrix with off diagonal terms may be visualized by mutual admittance but it may be impossible to physically realize (build) such a network. However, this does not prevent us from using this method to reduce a network for analysis purposes.

The other cut-sets whose voltage variables are node-datum

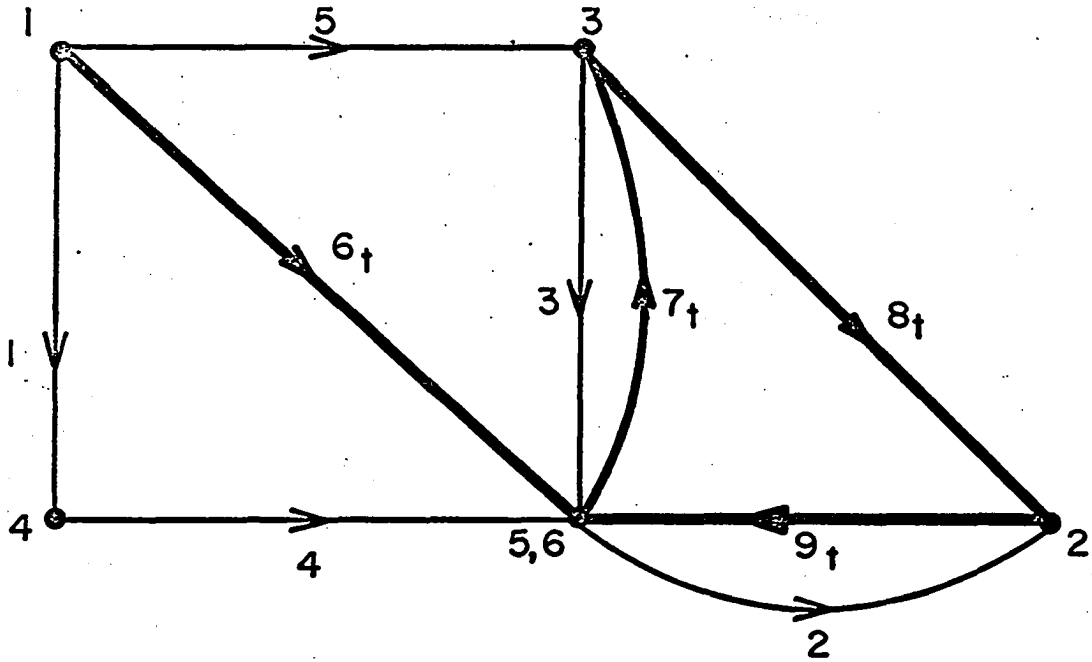

Figure 8. Transformed graph of Figure 7 with cut-set 5 deleted

voltage variables may be deleted by proper arrangement and partitioning of an appropriate non-singular transformation since the form of  $D$  depends upon the reference node chosen. However, even though the voltage of cut-set 3 is not a node-datum voltage,  $Q_{-3}$  is a cut-set matrix since a non-singular transformation and an incidence matrix may be found as

$$Q_{-3} = \begin{bmatrix} 1 & 0 & 0 & 0 \\ 0 & 1 & 0 & 0 \\ 0 & 0 & 1 & 0 \\ 0 & 1 & 1 & 1 \end{bmatrix} \begin{bmatrix} 1 & 0 & 1 & 0 & 0 & 1 & -1 & 1 & 0 \\ 0 & -1 & 0 & 0 & 0 & 0 & 0 & -1 & 1 \\ 0 & 0 & 0 & -1 & -1 & -1 & 0 & 0 & 0 \\ 0 & 1 & 0 & 1 & 1 & 0 & 1 & 0 & 0 \end{bmatrix}. \quad (65)$$

The graph of Equation 65 has no apparent connection with the original graph of Figure 7. This shows that if a cut-set voltage variable  $V_{q_i}$  is not a node-pair voltage variable, then the matrix formed by deleting row  $i$  from  $Q$  may be a cut-set matrix. This is a counterexample which proves that the sufficient conditions of Theorem 5 are not necessary for  $Q_{-i}$  to be a cut-set matrix.

The problem of determining whether a cut-set voltage variable is a node-pair voltage may be solved by writing a set of equations such as those given in Equation 62 (after first determining  $(D')^{-1}$ ) or a much easier method is contained in the interpretation of Theorem 6 which follows.

**Theorem 6.** Given a complete graph of  $v$  vertices with a set of  $v-1$  independent cut sets, then the voltage variable of cut-set  $i$  is the same as the voltage variable of edge  $j$  or the negative of the voltage variable of edge  $j$ , if and only if any edge  $j$  appears in only

one cut-set  $i$ .

Proof: Assume edge  $j$  appears in only one cut-set  $i$ , then  $Q$  contains a column  $j$  with only one non-zero element in row  $Q_i$ . Therefore, by Equation 35

$$V_j = \pm V_{q_i} \quad (66)$$

which completes the proof of the sufficiency of the theorem. For the other part of the theorem, assume that the voltage of edge  $j$  is related to the voltage of cut-set  $i$  by Equation 66. This can be true if row  $j$  of  $Q'$  has a  $\pm 1$  in column  $i$  and zeroes in the other  $v-2$  columns or if the combinations of the other cut-set voltages present in row  $j$  of  $Q'V_q$  are zero. Let us assume that the last mentioned case is true and the result is

$$V_j = k_1 V_{q_1} + k_2 V_{q_2} + \dots + k_\alpha V_{q_\alpha} \pm V_{q_i} \quad (67)$$

where  $k_1, k_2, \dots, k_\alpha$  are elements of row  $j$  of  $Q'$  and  $\alpha = v-2$ . Since we must satisfy Equation 66 we get

$$k_1 V_{q_1} + k_2 V_{q_2} + \dots + k_\alpha V_{q_\alpha} = 0, \quad (68)$$

but since the voltage variables of the cut-set  $V_q$  form an independent set of voltages, this can only be true if all the scalars  $k$  of Equation 68 are zero. Since the scalars  $k$  are the elements of row  $j$  of  $Q'$  and all are zero except the coefficient of  $V_{q_i}$ , then column  $j$  of  $Q$  must have only one non-zero element in row  $i$ . This completes the proof.

As an introduction to the next theorem let us define

the cut-set matrix  $Q$  as being a set of  $v-1$  independent cut-sets of the graph  $G$  with  $v$  vertices and  $e$  edges and the cut-set matrix  $Q_c$  as the matrix  $Q$  augmented by the columns corresponding to the fictitious edges of the complete graph  $G_c$ . We may now state the following theorem.

Theorem 7. Given a graph  $G$  and its cut-set matrix  $Q$  we may form  $G_c$  and  $Q_c$  (as described previously). If any edge or fictitious edge of  $G_c$  appears in only one cut-set, then this cut-set may be removed from  $Q$  and the remaining rows of  $Q$  will still be a cut-set matrix.

Proof: Assume edge  $j$  of  $G_c$  appears in only cut-set  $i$ , then by Theorem 6 the voltage variable of cut-set  $i$  of  $G_c$  is the same as the voltage variable of edge  $j$  or the negative of the voltage variable of edge  $j$ . Since the cut-set voltage variables of  $G$  are the same as those of  $G_c$  then by Theorem 5 it is obvious that  $Q$  with row  $i$  deleted is a cut-set matrix. This completes the proof.

An example showing that these conditions are not necessary is given in Section III B.

a. Relationship between node-pair and cut-set voltage variables Theorem 6 may be used for a graph that is not complete by assuming fictitious edges to make the graph complete. There will be a total number of  $\frac{v(v-1)}{2}$  edges of the graph since it was assumed that all parallel edges would be combined into one edge. In the complete graph all node-pair

voltages are edge voltages since there is an edge or fictitious edge between each pair of nodes. This provides us with an easy method of determining all cut-set voltage variables which are node-pair voltages by merely examining the graph with its  $v-1$  independent cut-sets or the cut-set matrix  $Q_c$ .

The edge voltages  $V$  of  $G$  are related to the cut-set voltage variables  $V_q$  by Equation 35 ( $V = Q'V_q$ ) and if Equation 35 is solved for  $V_q$  the result is

$$V_q = (QQ')^{-1}QV. \quad (69)$$

If  $Q_c$  is used in Equation 69 then the edge voltages are the voltages of the edges of  $G_c$  rather than the edges of  $G$ . It is usually easier to solve for the cut-set voltages by other methods since more time is involved in solving for  $(QQ')^{-1}Q$ . These methods will be discussed next.

By proper arrangement of columns, any cut-set matrix may be transformed into a fundamental cut-set matrix  $Q_f$  by pre-multiplication by a suitable non-singular matrix  $E$  of order  $v-1$  so

$$Q_f = EQ \quad (70)$$

where

$$Q_f = [U \mid Q_{f12}]. \quad (71)$$

If Equation 70 and 71 are substituted into Equation 35 the result is

$$V = \begin{bmatrix} U \\ Q_{f_{12}}' \end{bmatrix} (E^{-1})' V_q \quad (72)$$

and if  $V$  is partitioned then we get

$$\begin{bmatrix} V_{11} \\ V_{21} \end{bmatrix} = \begin{bmatrix} (E^{-1})' \\ Q_{f_{12}}' (E^{-1})' \end{bmatrix} V_q \quad (73)$$

where  $V_{11}$  represents the edge voltages of  $v-1$  edges forming a tree of  $G$  and  $V_{21}$  represents the edge voltages of the remaining  $e - (v-1)$  edges.

If Equation 73 is solved for  $V_q$  we get

$$V_q = E' V_{11} \quad (74)$$

which shows that the  $v-1$  cut-set voltages are related to  $v-1$  edge voltages by  $E'$ . This provides a much easier method of solving for the cut-set voltages since  $E'$  is relatively easy to form. As shown by Equation 70,  $E$  represents those row operations which will transform the first  $v-1$  columns (after rearranging column ordering if necessary) of  $Q$  into a unit matrix as

$$EQ_{11} = U. \quad (75)$$

Also

$$E'Q_{11}' = U \quad (76)$$

or

$$Q_{11}'E' = U \quad (77)$$

and for  $E'$  we get

$$E' = (Q_{11}^{-1})' \quad (78)$$

This method of solving for  $E'$  requires us to identify a tree in order to form the columns of  $Q_{11}$  from  $Q$ . As the rank of  $G$  increases, the labor involved in finding  $E'$  may not be justified and Equation 69 may be a more direct method of solving for the cut-set voltage variables.

Another way of solving for the cut-set voltage variables results from premultiplying Equation 35 by a matrix  $N$  (not necessarily non-singular) as

$$NV = NQ'V_q \quad (79)$$

such that in any row of  $NQ'$  a single plus one appears in column  $i$  (and zeroes in the other columns) of  $NQ'$ . Thus, the voltage-variable of cut-set  $i$  has been determined in terms of a combination of edge voltages. Therefore, if we can combine rows of  $Q'$  such that a single plus one appears in column  $i$  and zeroes appear in the other columns of the combination then we have found  $V_{q_i}$  in terms of the voltages of the edges or rows of  $Q'$  that were combined. Equivalently, if can combine columns of  $Q$  such that a single plus one appears in row  $i$  and zeroes appear in the other rows of the combination then we have found  $V_{q_i}$  in terms of the voltages of the edges or columns of  $Q$  that were combined. This method has an advantage over the method given by Equation 74 since we do not need to choose a tree of  $G$ . By Theorem 6 we know that a cut-set may be deleted from  $Q$  with the remaining rows of  $Q$  still forming a cut-set matrix if the voltage variable of that



cut-set is a node-pair voltage. Therefore, by the above method we can determine the voltage variable of any cut-set without completely solving for  $N$  of Equation 79. However, the cut-set voltage variable may be a combination of voltages of a set of edges which is not minimal. The edges of a circuit may be included as a subset and hence this subset of voltages will sum to zero by Kirchhoff's Voltage Law. It may be possible to use this scheme to devise an algorithm whereby a minimal set of edges are chosen such that we could find the edges of a tree for any given cut-set matrix but this will not be explored.

As an example let us use the graph of Figure 7 with a cut-set matrix given by Equation 58. Let us choose edges 1, 2, and 4 since they have a single 1 per column and columns 3 and 6 to complete our first  $v-1$  columns of  $Q$ . The reason for not choosing edge 5 is apparent since the first 5 columns of  $Q$  do not have rank 5 (a row of zeroes is present). Equivalently, we note that edges 1 through 5 do not form a tree of the graph shown in Figure 7. The matrix  $E'$  is easily formed for this choice as

$$E' = \begin{bmatrix} 1 & 0 & 0 & 0 & 0 \\ 0 & -1 & 0 & 0 & 0 \\ -1 & 0 & 1 & 0 & 0 \\ 0 & 0 & 0 & -1 & 0 \\ 1 & 0 & 0 & 1 & -1 \end{bmatrix} \quad (80)$$

and when substituted into Equation 74 the result is

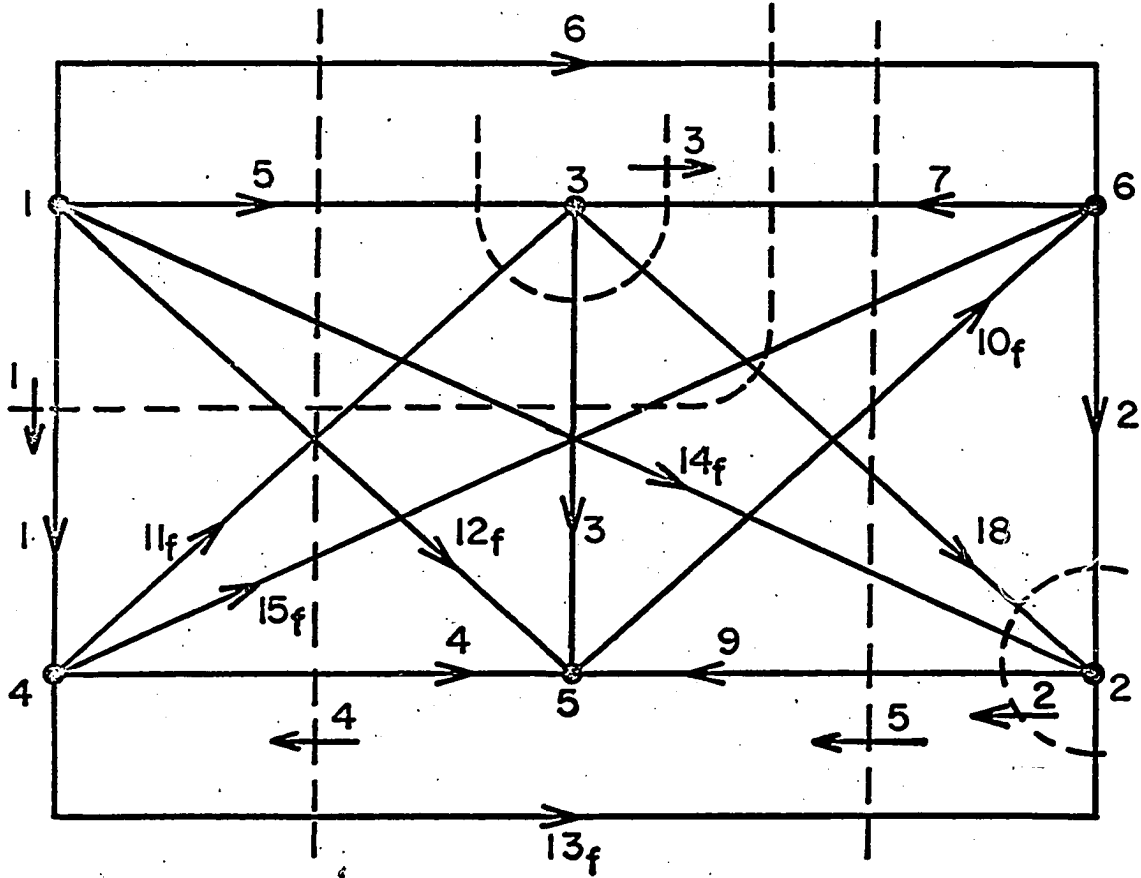

Figure 9. Complete graph of Figure 7

which again agrees with Equation 81. However E' of Equation 83 is more difficult to form than E' of Equation 80.

As one final example let us find the cut-set voltage variables of Figure 10 by using Equation 79. The cut-set matrix is given in Equation 90. If we add column 1 and column 5 and divide by two we get a single one in row 1 of this combination so

$$V_{q_1} = \frac{V_1 + V_5}{2} \quad (85)$$

and if we subtract column 5 from column 1 and divide by two we get a single one in row 3 of this combination so

$$V_{q_3} = \frac{V_1 - V_5}{2} \quad (86)$$

We also notice that column 7 contains a single minus one in row 4 so

$$V_{q_4} = -V_7 \quad (87)$$

To find  $V_{q_2}$  let us choose column 4 (any column with a non-zero element in row 2 would be all right) and write an equation as

$$V_4 = -V_{q_2} - V_{q_3} + V_{q_4} \quad (88)$$

and when Equations 86 and 87 are substituted into Equation 88 we get

$$V_{q_2} = -\frac{V_1}{2} - V_4 + \frac{V_5}{2} - V_7 \quad (89)$$

This section merely points out some of the short-cuts which may be used to determine the cut-set voltage variables in terms of the edge voltages. The one point to remember is

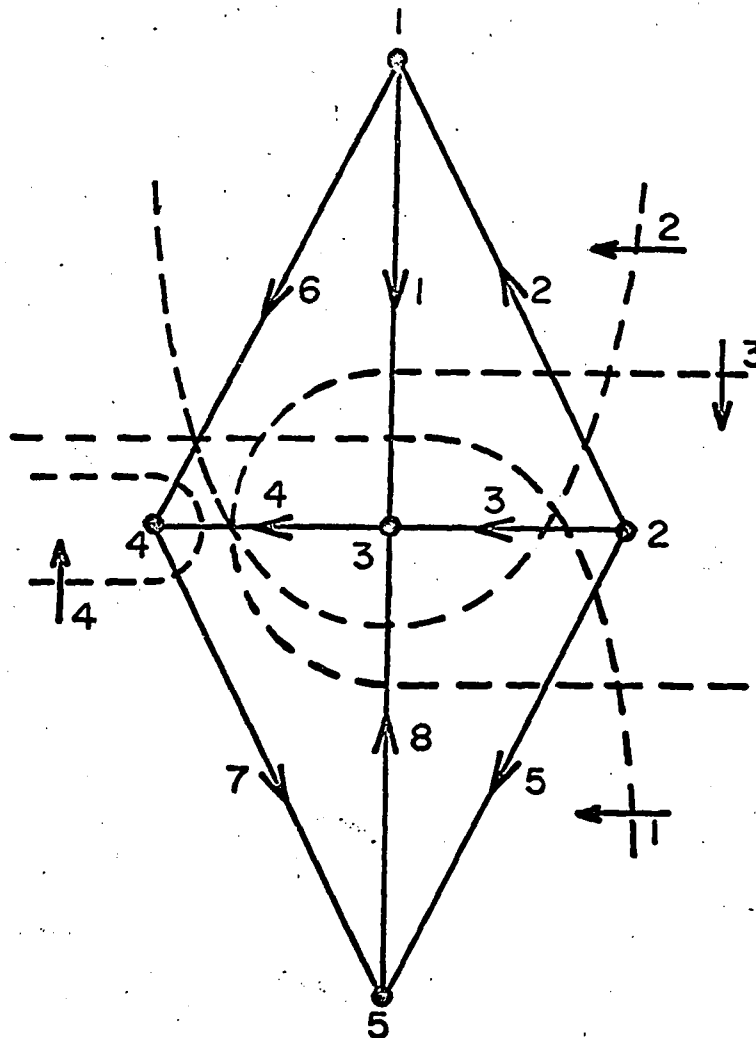

Figure 10. Directed graph with four independent cut-sets

that we have  $e$  equations (columns or edges) and  $v-1$  ( $v-1 < e$ ) unknowns (rows or cut-sets) so as in any system of equations there may be some sets of equations which yield a solution with less effort than another set.

b. Cut-set matrices of non-oriented graphs This section will be devoted to several examples to show that if we change all minus ones of  $Q$  to plus ones then  $Q$  may not be proper for the non-oriented graph. Likewise,  $Q$  may not be a cut-set matrix of a directed graph but if all minus ones of  $Q$  are replaced by plus ones then  $Q$  may be a cut-set matrix of a non-oriented graph.

As established By Seshu and Reed (13), a set of cut-sets that are independent over the real field may not be independent over the field mod 2 when orientations are removed.

As an example let us consider the directed graph of Figure 10 with four independent cut-sets as illustrated. If we form  $Q$ , the result is

$$Q = \begin{matrix} & \begin{matrix} 1 & 2 & 3 & 4 & 5 & 6 & 7 & 8 \end{matrix} \\ \begin{matrix} 1 \\ 2 \\ 3 \\ 4 \end{matrix} & \begin{bmatrix} 1 & 0 & 1 & 0 & 1 & 1 & 0 & 0 \\ 0 & 1 & 1 & -1 & 0 & -1 & 0 & 1 \\ 1 & -1 & 0 & -1 & -1 & 0 & 0 & 1 \\ 0 & 0 & 0 & 1 & 0 & 1 & -1 & 0 \end{bmatrix} \end{matrix} \quad (90)$$

and since edge 7 appears in only cut-set four, cut-set four may be deleted and the remaining rows  $Q_{-4}$  still form a cut-set matrix describing the graph illustrated in Figure 11. However, if we replace all minus ones by plus ones in  $Q_{-4}$  we get for the corresponding mod 2 matrix of the non-oriented graph,

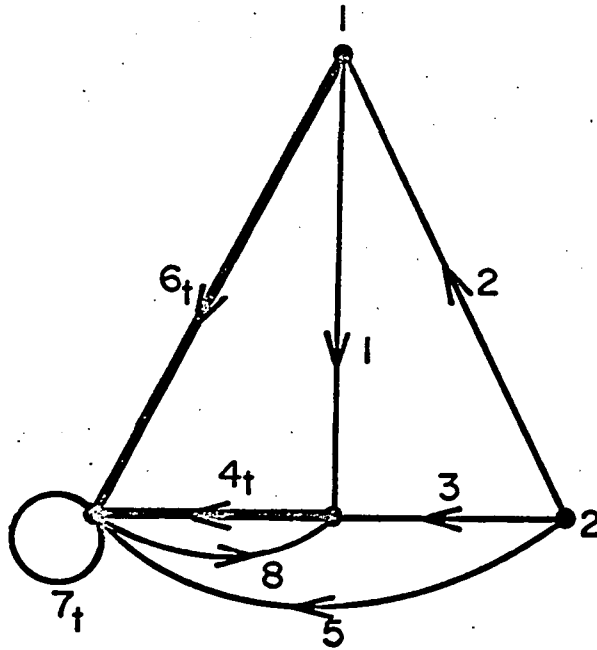

Figure 11. Graph of Figure 10 with cut-set four deleted

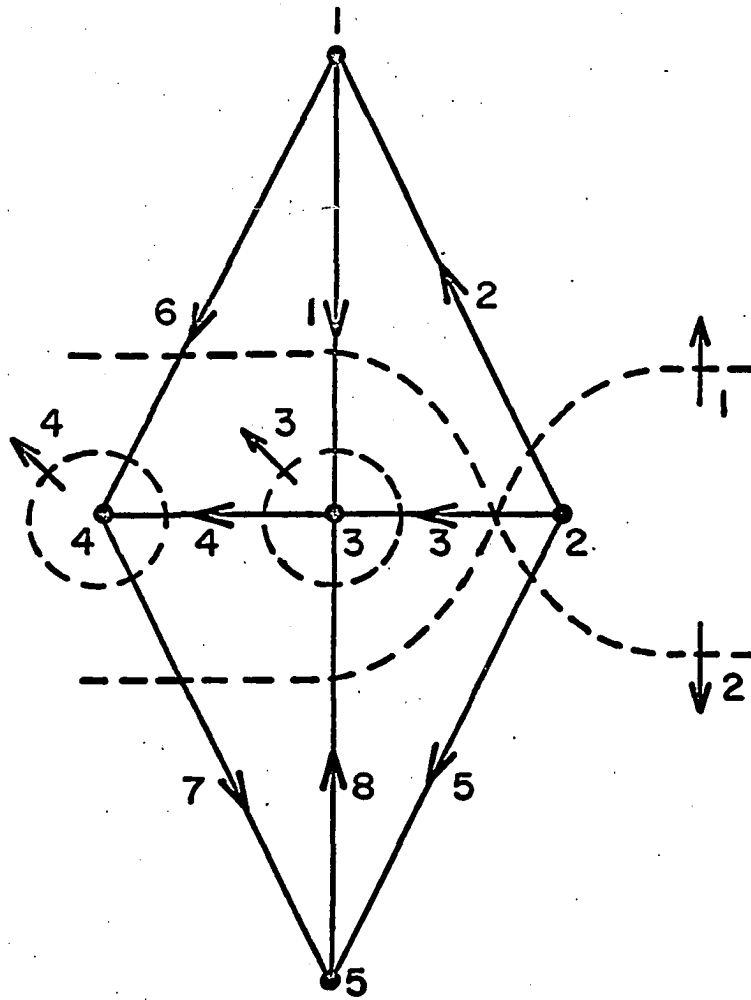

Figure 12. Directed graph with four different independent cut-sets

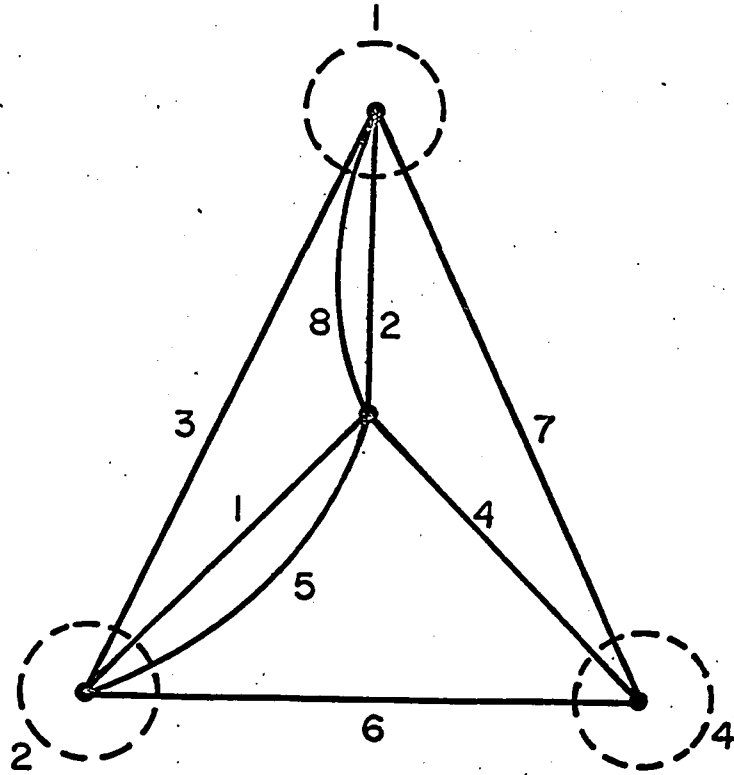

Figure 13. Non-oriented graph described by Equation 94



From Equation 40

$$V_{y_q} = -(Q_y Y Q_y')^{-1} Q_y Y Q_x' V_{x_q} \quad (96)$$

and when Equation 96 is substituted into Equation 95 the edge currents are

$$I = [Y - Y Q_y' (Q_y Y Q_y')^{-1} Q_y Y] Q_x' V_{x_q} - J. \quad (97)$$

The edge currents  $I_a$  after the transformation are given by

$$I_a = Y_a V_a - J_a = Y_a Q_a' V_{q_a} - J_a \quad (98)$$

where the source currents  $J_a$  are the same as the source currents  $J$ , the element admittance matrix  $Y_a$  is now  $Y_y$ , the cut set matrix  $Q_a$  after the transformation is  $Q_x$  since the cut-sets  $Q_y$  have been deleted, and the cut-set voltage variables have all been reduced to zero except  $V_{x_q}$  so  $V_{q_a} = V_{x_q}$ . Therefore, it is obvious that the edge currents  $I$  given by Equation 97 are the same as those given by Equation 98. Thus, the edge currents remain invariant under the transformation.

The general element admittance matrix will be developed as needed in the example that follows. Let us begin with a simple network and its graph as illustrated in Figure 14 and Figure 15 respectively. If we choose cut-sets such that each source edge (edge 6 in the example) is included in only one cut-set then we may reduce the network to an equivalent network without disturbing the sources. If we direct the edges to agree with the first cut-set to be deleted we get

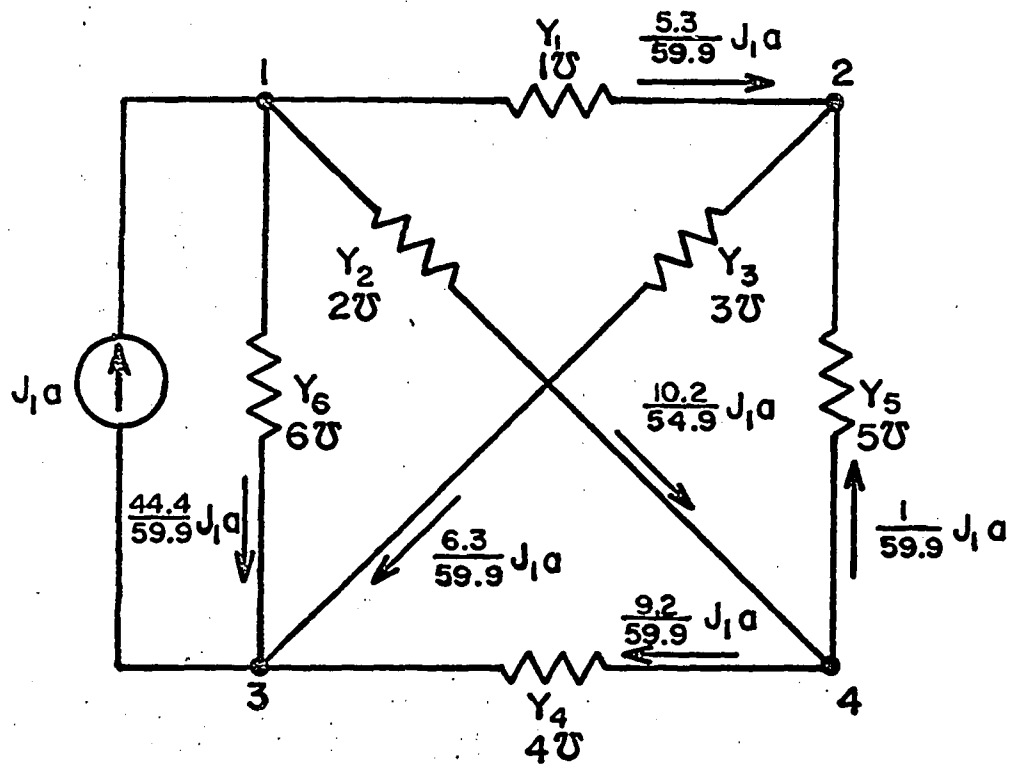

Figure 14. A network with corresponding element currents

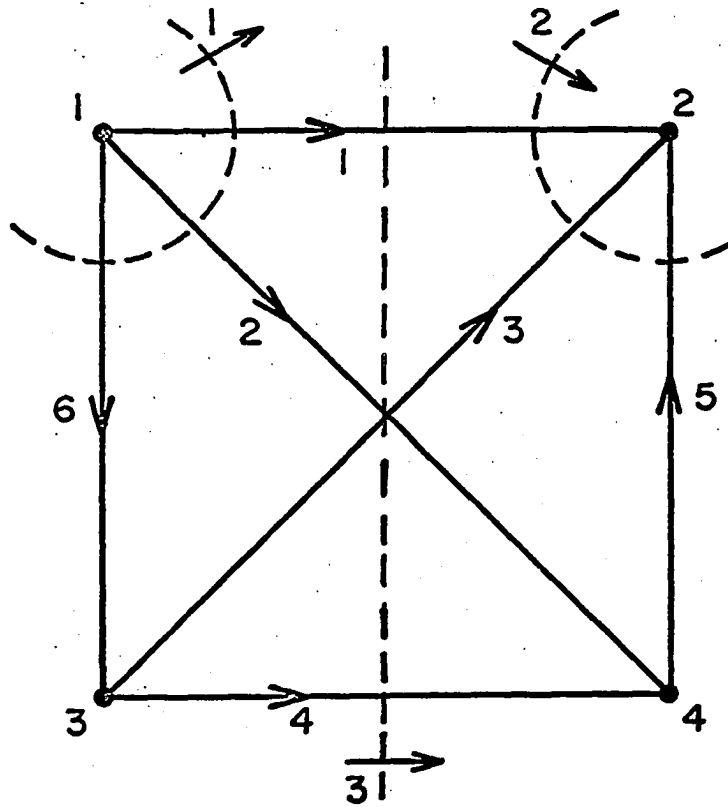

Figure 15. Graph of network illustrated in Figure 14

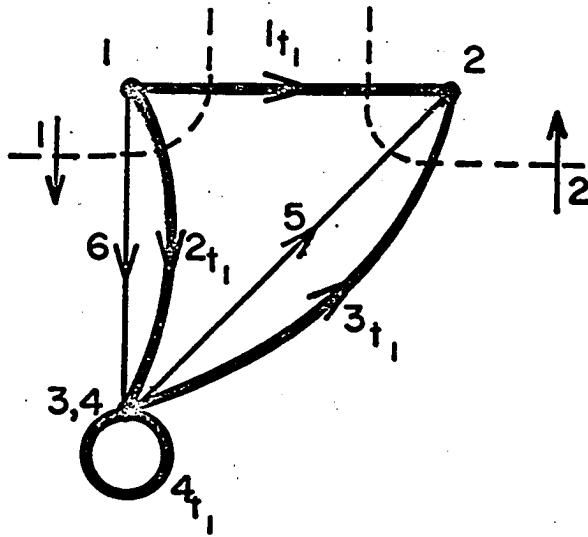

Figure 16. Graph of network after deletion of cut-set 3

first  $s$  rows and columns of  $Y_{y_1}$ . If the orientation of the edges of  $Q_{y_2}$  do not result in plus ones in the  $s$  columns then the orientations of these edges (where a minus one appears) may be reversed and the corresponding sign changes made in  $Y_{y_1}$ . This is not necessary when making a transformation but is convenient in terms of deriving a general element admittance matrix.

Let

$$Y_{y_1} = [y_{ij}] \quad (103)$$

where

$$y_{ij} = y_{ji} \quad (104)$$

and form the terms of Equation 102. The term

$$Q_{y_2} Y_{y_1} Q_{y_2}' = \sum_{i=1}^s \sum_{j=1}^s y_{ij} = \Sigma' y_{ij} \quad (105)$$

and since this is a scalar its inverse is its reciprocal so

we may bring together and combine the premultiplier  $Y_{y_1} Q_{y_2}'$

and the postmultiplier  $Q_{y_2} Y_{y_1}$  as

$$Y_{y_1} Q_{y_2}' Q_{y_2} Y_{y_1} = \begin{bmatrix} \Sigma y_{11} \\ \Sigma y_{21} \\ \vdots \\ \Sigma y_{e1} \end{bmatrix} [\Sigma y_{i1} \quad \Sigma y_{i2} \quad \dots \quad \Sigma y_{ie}] \quad (106)$$

where  $\Sigma$  is the summation defined by Equation 23 ( $\Sigma = \sum_{i=1}^s$ ).

This gives a general expression for  $Y_{y_2}$  as

$$Y_{y_2} = \begin{bmatrix} y_{11} - \frac{\Sigma y_{i1} \Sigma y_{i1}}{\Sigma' y_{ij}} & y_{12} - \frac{\Sigma y_{i1} \Sigma y_{i2}}{\Sigma' y_{ij}} & \dots & y_{1e} - \frac{\Sigma y_{i1} \Sigma y_{ie}}{\Sigma' y_{ij}} \\ y_{21} - \frac{\Sigma y_{i2} \Sigma y_{i1}}{\Sigma' y_{ij}} & y_{22} - \frac{\Sigma y_{i2} \Sigma y_{i2}}{\Sigma' y_{ij}} & \dots & y_{2e} - \frac{\Sigma y_{i2} \Sigma y_{ie}}{\Sigma' y_{ij}} \\ y_{e1} - \frac{\Sigma y_{ie} \Sigma y_{i1}}{\Sigma' y_{ij}} & y_{e2} - \frac{\Sigma y_{ie} \Sigma y_{i2}}{\Sigma' y_{ij}} & \dots & y_{ee} - \frac{\Sigma y_{ie} \Sigma y_{ie}}{\Sigma' y_{ij}} \end{bmatrix}$$

Equation 107 may be used at each step to find the element admittance matrix in terms of the  $s$  edges of the cut-set. Equation 107 reduces to Equation 26 when  $Y_{y_1}$  is a diagonal matrix. It may be more convenient to express Equation 107 as the difference between two matrices such that

$$Y_{y_2} = \frac{1}{\Sigma' y_{ij}} [Y_1 - Y_2] \quad (108)$$

where

$$Y_1 = \Sigma' y_{ij} Y_{y_1} \quad (109)$$

and

$$Y_2 = \begin{bmatrix} \Sigma y_{i1} \Sigma y_{i1} & \Sigma y_{i1} \Sigma y_{i2} & \dots & \Sigma y_{i1} \Sigma y_{ie} \\ \Sigma y_{i2} \Sigma y_{i1} & \Sigma y_{i2} \Sigma y_{i2} & \dots & \Sigma y_{i2} \Sigma y_{ie} \\ \dots & \dots & \dots & \dots \\ \Sigma y_{ie} \Sigma y_{i1} & \Sigma y_{ie} \Sigma y_{i2} & \dots & \Sigma y_{ie} \Sigma y_{ie} \end{bmatrix} \quad (110)$$

At this time let us interpret the various terms of  $Y_{y_2}$ . Given the element admittance matrix  $Y_{y_1}$ , then since  $\Sigma' y_{ij}$  is the sum of all elements in the first  $s$  columns and  $s$  rows of  $Y_{y_1}$ , we can find  $Y_1$  very easily. The general term  $\Sigma y_{ik}$  is the sum of the first  $s$  elements in column  $k$  of  $Y_{y_1}$ .

Therefore,  $Y_2$  may be easily formed and the difference  $Y_1 - Y_2$  yields  $Y_{y_2}$ .

Now returning to the example, let us delete cut-set 2 so we will arrange  $Q_{x_1}$  as

$$Q_{x_1} = \begin{matrix} & \begin{matrix} 1 & 3 & 5 & 2 & 4 & 6 \end{matrix} \\ \begin{matrix} 1 \\ 2 \end{matrix} & \begin{bmatrix} 1 & 0 & 0 & 1 & 0 & 1 \\ 1 & 1 & 1 & 0 & 0 & 0 \end{bmatrix} \end{matrix} = \begin{bmatrix} Q_{x_2} \\ -I_2 \\ Q_{y_2} \end{bmatrix} \quad (111)$$

where edge orientation of cut-set  $Q_{y_2}$  was chosen to produce  $s$  plus ones in the first  $s$  columns. In general it is not possible to choose all cut-sets to fit the general form as described and it is necessary to make corresponding sign changes in the element admittance matrix. The element admittance matrix may be arranged in the proper form to apply Equation 107 by ordering rows and columns of Equation 100 to agree with the order of edges chosen in Equation 111. The element admittance matrix  $Y_{y_1}$  then becomes

$$Y_{y_1} = \begin{matrix} & \begin{matrix} 1 & 3 & 5 & 2 & 4 & 6 \end{matrix} \\ \begin{matrix} 1 \\ 3 \\ 5 \\ 2 \\ 4 \\ 6 \end{matrix} & \begin{bmatrix} 0.9 & -0.3 & 0 & -0.2 & -0.4 & 0 \\ -0.3 & 2.1 & 0 & -0.6 & -1.2 & 0 \\ 0 & 0 & 5 & 0 & 0 & 0 \\ -0.2 & -0.6 & 0 & 1.6 & -0.8 & 0 \\ -0.4 & -1.2 & 0 & -0.8 & 2.4 & 0 \\ 0 & 0 & 0 & 0 & 0 & 6 \end{bmatrix} \end{matrix}, \quad (112)$$

and since

$$\sum y_{ij} = 7.4$$

we get

$$Y_1 = \begin{bmatrix} 6.66 & -2.22 & 0 & -1.48 & -2.96 & 0 \\ -2.22 & 15.54 & 0 & -4.44 & -8.88 & 0 \\ 0 & 0 & 37.0 & 0 & 0 & 0 \\ -1.48 & -4.44 & 0 & 11.84 & -5.92 & 0 \\ -2.96 & -8.88 & 0 & -5.92 & 17.76 & 0 \\ 0 & 0 & 0 & 0 & 0 & 44.4 \end{bmatrix} \quad (113)$$

The matrix  $Y_2$  is

$$Y_2 = \begin{bmatrix} 0.36 & 1.08 & 3 & -0.48 & -0.96 & 0 \\ 1.08 & 3.24 & 9 & -1.44 & -2.88 & 0 \\ 3 & 9 & 25 & -4 & -8 & 0 \\ -0.48 & -1.44 & -4 & 0.64 & 1.28 & 0 \\ -0.96 & -2.88 & -8 & 1.28 & 2.56 & 0 \\ 0 & 0 & 0 & 0 & 0 & 0 \end{bmatrix} \quad (114)$$

and

$$Y_{y_2} = \frac{1}{7.4} \begin{bmatrix} 1 & 3 & 5 & 2 & 4 & 6 \\ 6.3 & -3.3 & -3 & -1 & -2 & 0 \\ -3.3 & 12.3 & -9 & -3 & -6 & 0 \\ -3 & -9 & 12 & 4 & 8 & 0 \\ -1 & -3 & 4 & 11.2 & -7.2 & 0 \\ -2 & -6 & 8 & -7.2 & 15.2 & 0 \\ 0 & 0 & 0 & 0 & 0 & 44.4 \end{bmatrix} \quad (115)$$

Therefore, Equation 115 is the element admittance matrix of a network whose graph is described by  $Q_{x_2}$  of Equation 111 and illustrated in Figure 17.

Let us now see how the edge currents of the network corresponding to Figure 17 agree with those values given in Figure 14. The equation describing the network is

$$I_{x_2} = Q_{x_2} Y_{y_2} Q_{x_2}' V_{x_2} \quad (116)$$

where

$$I_{x_2} = J_1 \quad (117)$$

and

$$V_{x_2} = V_{q_1} = V_{13} \quad (118)$$

Equation 116 may be written as



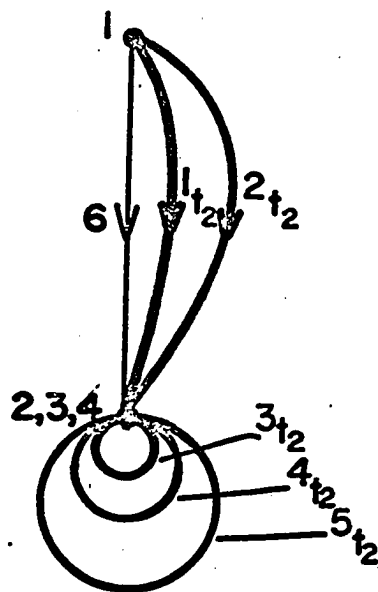

Figure 17. Graph of network after deletion of cut-sets 2 and 3

$$J_1 = \frac{59.9}{7.4} V_{13} \quad (119)$$

which gives an input admittance of  $\frac{59.9}{7.4}$  mhos between terminals 1 and 2 of Figure 17 which is the input admittance between the corresponding terminals in Figure 14. The edge voltages  $V_a$  after the transformation are

$$V_a = \begin{bmatrix} V_1 \\ V_3 \\ V_5 \\ V_2 \\ V_4 \\ V_6 \end{bmatrix} = \begin{bmatrix} V_{13} \\ 0 \\ 0 \\ V_{13} \\ 0 \\ V_{13} \end{bmatrix} \quad (120)$$

since edges 1, 2, and 6 are in parallel and edges 3, 4, and 5 form self loops as illustrated in Figure 17. This gives for the edge currents  $I_a$  (as given by Equation 98)

$$I_a = \begin{bmatrix} I_1 \\ I_1 \\ I_3 \\ I_5 \\ I_2 \\ I_4 \\ I_6 \end{bmatrix} = \frac{1}{7.4} \begin{bmatrix} 5.3 \\ -6.3 \\ 1 \\ 10.2 \\ -9.2 \\ 44.4 \end{bmatrix} V_{13} - \begin{bmatrix} 0 \\ 0 \\ 0 \\ 0 \\ 0 \\ 0 \\ J_1 \end{bmatrix} \quad (121)$$

or in terms of  $J_1$  (from Equation 119)

$$\begin{bmatrix} I_1 \\ I_1 \\ I_3 \\ I_5 \\ I_2 \\ I_4 \\ I_6 \end{bmatrix} = \frac{1}{59.9} \begin{bmatrix} 5.3 \\ -6.3 \\ 1.0 \\ 10.2 \\ -9.2 \\ 44.4 \end{bmatrix} J_1 - \begin{bmatrix} 0 \\ 0 \\ 0 \\ 0 \\ 0 \\ 0 \\ J_1 \end{bmatrix} \quad (122)$$

which agrees with those values given in Figure 14.

Therefore, this example demonstrates the previously established invariance of edge currents and we have reduced the original graph that was shown in Figure 15 to an equivalent graph that is illustrated in Figure 17.

## IV. SUGGESTED RESEARCH PROBLEMS

Several research problems can be suggested as a result of this investigation. (a) If one row  $i$  is deleted from a cut-set matrix  $Q$ , then the remaining rows form a cut-set matrix  $Q_{-i}$  if the cut-set deleted satisfies the sufficient conditions of Theorem 7. A counterexample is given to show that these conditions are not necessary conditions. It would be desirable to find the necessary and sufficient conditions for the existence of this cut-set matrix, preferably in terms of readily recognized graph properties. In the counterexample given, the graph represented by  $Q_{-1}$  of Equation 65 does not appear to be related to the original graph illustrated in Figure 7. If edge 10 is added to Figure 7 from vertex 1 to vertex 2 then  $Q_{-3}$  becomes

$$Q_{-3} = \begin{matrix} & \begin{matrix} 1 & 2 & 3 & 4 & 5 & 6 & 7 & 8 & 9 & 10 \end{matrix} \\ \begin{matrix} 1 \\ 2 \\ 4 \\ 5 \end{matrix} & \left[ \begin{array}{cccccccccc} 1 & 0 & 1 & 0 & 0 & 1 & -1 & 1 & 0 & 1 \\ 0 & -1 & 0 & 0 & 0 & 0 & 0 & -1 & 1 & -1 \\ 0 & 0 & 0 & -1 & -1 & -1 & 0 & 0 & 0 & -1 \\ 0 & 0 & 0 & 0 & 0 & -1 & 1 & -1 & -1 & -1 \end{array} \right] \end{matrix} \quad (123)$$

which is not a cut-set matrix. Therefore, when an edge is added,  $Q_{-3}$  is no longer a cut-set matrix. This leads one to believe that the sufficient conditions may also be necessary conditions for a complete graph. Adding different columns (adding more edges to the graph) to the cut-set matrix may give some insight into how the properties of the graph change as we add edges.

(b) In section IIIB2c, an example was given where a network with one source was reduced to an equivalent network with an element admittance matrix given by Equation 115. The general element admittance matrix (with proper orientation of edges) is given by Equation 107 as each cut-set is deleted. If this procedure could be reversed, then it should be possible to use this method in the reverse fashion for network synthesis. For example, given an element admittance matrix, we should be able to add one cut-set at a time until we have constructed a cut-set matrix  $Q$  and a diagonal admittance matrix which will describe the network.

## V. SUMMARY

This investigation provides a new approach to transformations in terms of graph theory. This approach is used to provide a new derivation for the familiar star-to-mesh transformation in terms of the incidence matrix  $A$  of the graph and is then extended to a more general cut-set to mesh transformation using the cut-set matrix  $Q$ .

In the last method a cut-set is deleted from  $Q$  (the edges of the cut-set are transformed) and the matrix of the remaining rows of  $Q$ , if it forms a cut-set matrix, defines an equivalent graph described by a transformed element admittance matrix  $Y_y$ . The necessary and sufficient conditions are given for a transformation to be physically realizable with passive elements. If a transformation is not physically realizable, then the sufficient conditions are given for a cut-set matrix with one row deleted to be a cut-set matrix. In this case a transformation is hypothetically realized with mutual admittances. These conditions depend upon whether the voltage variable of the cut-set deleted is a node-pair voltage variable. A method is given whereby the cut-set voltage variables can be determined in terms of node-pair voltages.

An example is given where successive transformations reduce a graph to an equivalent graph. The interpretation of these steps and of the structure of the graph and the element admittance matrix may be useful in network

synthesis as well as network analysis. It might be possible to devise a synthesis procedure whereby we approach the analysis problem in the reverse order and hence determine a network for a given admittance matrix.

## VI. BIBLIOGRAPHY

1. Boast, Warren B. Principles of electric and magnetic circuits. New York, N.Y., Harper and Brothers. c1950.
2. Finkbeiner, Daniel T. Introduction to matrices and linear transformations. San Francisco, Calif., W. H. Freeman and Company. c1960.
3. Gould, R. Graphs and vector spaces. Journal of Mathematics and Physics 37: 193-214. c1959.
4. Guillemin, Ernst A. Introductory circuit theory. New York, N.Y., John Wiley and Sons, Inc. c1953.
5. Hohn, Franz E. Elementary matrix algebra. New York, N.Y., The Macmillan Company. c1958.
6. Huelsman, Lawrence P. Circuits matrices and linear vector spaces. New York, N.Y., McGraw Hill Book Co., Inc. c1963.
7. Kim, Wan Hee and Chien, Robert Tien-Wen. Topological analysis and synthesis. New York, N.Y., Columbia University Press. c1962.
8. Lofgren, L. Irredundant and redundant Boolean branch-networks. Institute of Radio Engineers Transactions Circuit Theory CT-6: 158-175. 1959.
9. Mayeda, W. Necessary and sufficient conditions for realizability of cut-set matrices. Institute of Radio Engineers Transactions Circuit Theory CT-7: 79-81. 1960.
10. Mayeda, W. Realizability of fundamental cut-set matrices of oriented graphs. Institute of Electrical and Electronic Engineers Transactions Circuit Theory CT-10: 133-134. 1963.
11. Reed, Myril B. Alternating current circuit theory. New York, N.Y., Harper and Brothers. c1956.
12. Reed, Myril B. Foundation for electric network theory. Englewood Cliffs, N.J., Prentice-Hall, Inc. c1961.
13. Seshu, Sundaram and Reed, Myril B. Linear graphs and electrical networks. Reading, Mass., Addison-Wesley Publishing Co., Inc. c1961.



14. Shekel, J. Matrix representation of transistor circuits. Institute of Radio Engineers Proceedings 40: 1493-1497. 1952.
15. Tutte, W. T. An algorithm for determining whether a given binary matroid is graphic. American Mathematical Society Proceedings 11: 905-917. 1960.

## VII. ACKNOWLEDGEMENT

The author wishes to express his appreciation to Dr. H. W. Hale, his major professor for acquainting him with the area of linear graph theory, and for his helpful suggestions and able assistance that was rendered during the preparation of this thesis.